

OWNER'S MANUAL

3 9 0 0
With Serial
NO 1117 On

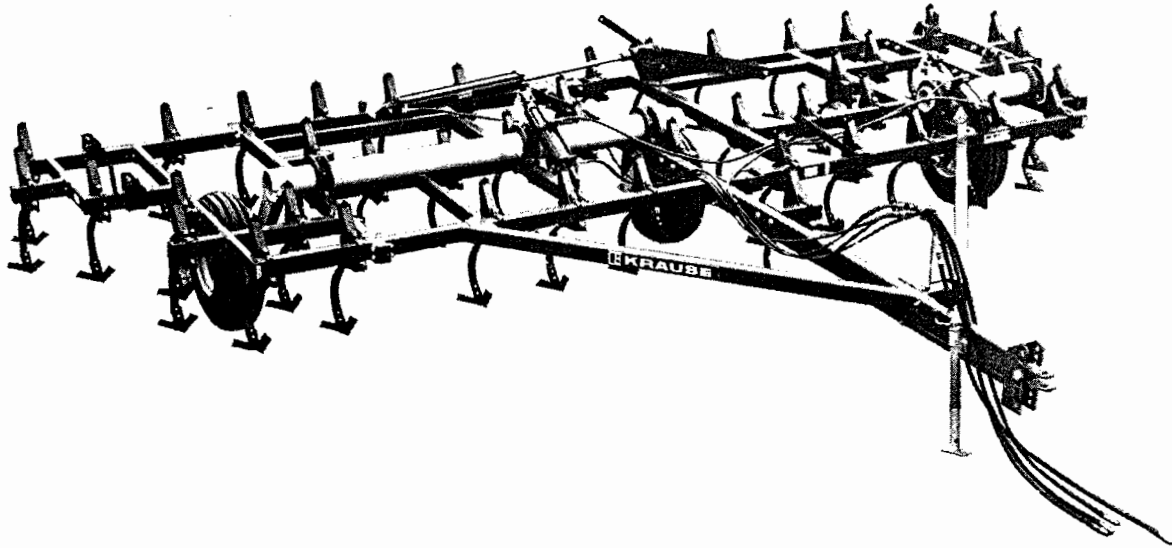

TWO SECTION FIELD CULTIVATOR

M O D E L

3940 - 32, 34, 36, 38, 40, 42 & 44 SHANK

KRAUSE

305 SOUTH MONROE ST. HUTCHINSON, KANSAS 67501

11/82

CONGRATULATIONS

You have just purchased a quality designed and manufactured Krause tillage tool. Advanced features have been designed into the implement for modern farming operations. As with any investment, a return is expected, and the return received from this investment will be in the form of maximum tillage performance during many years of dependable service.

In order to maintain quality performance of the new Krause implement, it is important that all the information in the manual be reviewed and studied carefully before operation. The contents provide operating instructions, maintenance instructions and how to make adjustments.

SAFETY ALERT SYMBOL

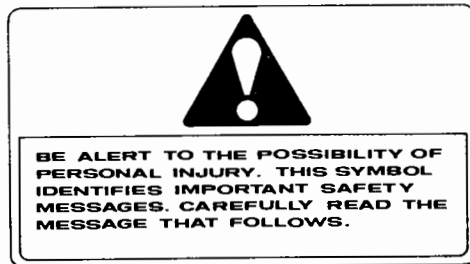

MODEL NUMBER _____

SERIAL NUMBER _____

PURCHASE RECORD--DATE _____

Krause Plow Corporation reserves the right to change any design or specifications without notice or obligations.



SAFETY FIRST

Be observant and safety minded. Recognize and correct or avoid hazardous conditions before an accident can happen. Most accidents can be prevented by practicing simple fundamental safety rules.

1. Read and understand the implement and tractor owner's manuals before operating.
2. Be sure safety decals and reflectors are clean and in place.
3. Do not climb or walk on gangs or frames or tires.
4. Never position yourself under any portion of implement unless the transport lock is engaged or entire unit is lowered to the ground.
5. Stop engine before leaving operator's position to adjust, lubricate, clean or unclog the machine.
6. Do not stand between the implement and tractor unless tractor brakes are locked and engine is shut off.
7. Do not stand on or straddle a tongue when unhitching.
8. Always store a winged implement with the wings down.
9. Never remove locking pins until hydraulic cylinders and lines are full of oil and free of air. See operating instructions for proper method of removing air.
10. Never use machinery until all safety devices are in place.
11. Release all hydraulic pressure before shutdown periods.
12. Comply with Federal, State and local laws.
13. Use a Slow-Moving-Vehicle emblem when roading.
14. Always use a safety chain of tensile strength equal to the gross weight of the implement and attachments when roading.
15. Towing vehicle weight must exceed weight of towed implement.
16. Check wheel bolts before and during transport.
17. Always use wing locks and road locks to hold raised positions.
18. Never permit riders on implement.
19. Do not road an implement over 15 miles per hour on the best surface conditions. Reduce speed when going up or down hills and approaching ditches or corners.
20. Keep small children away from farm equipment.
21. Never modify an implement without permission from the Krause Engineering Department.
22. Always use authorized Krause parts.

Warranty

KRAUSE PLOW CORPORATION

HUTCHINSON, KANSAS

THE KRAUSE PLOW CORPORATION, HUTCHINSON, KANSAS, EXPRESSLY WARRANTS EACH NEW PRODUCT MANUFACTURED BY IT TO BE FREE FROM DEFECTS IN MATERIAL AND WORKMANSHIP UNDER NORMAL USE AND SERVICE FOR A PERIOD OF ONE YEAR AFTER DELIVERY TO THE ORIGINAL RETAIL PURCHASER OR FIRST USER OF THE PRODUCT.

KRAUSE'S OBLIGATION UNDER THIS WARRANTY IS LIMITED TO REPAIRING AND/OR REPLACING, AT ITS OPTION, ANY PART OR PARTS WITHIN THE APPLICABLE ONE YEAR PERIOD, AS SET OUT ABOVE, WHICH SHALL BE RETURNED BY THE OWNER OR ANY KRAUSE AUTHORIZED DEALER TO THE FACTORY AND WHICH UPON EXAMINATION SHALL DISCLOSE TO KRAUSE'S SATISFACTION TO BE DEFECTIVE.

KRAUSE MAY, AT ITS OPTION, ELECT TO GRANT ADJUSTMENTS IN THE FIELD THROUGH AN AUTHORIZED REPRESENTATIVE AND MAY THEREBY ELECT TO WAIVE THE REQUIREMENT THAT PARTS BE RETURNED TO KRAUSE'S FACTORY.

A NEW WARRANTY PERIOD IS NOT ESTABLISHED FOR REPLACEMENTS. REPLACEMENTS ARE WARRANTED FOR THE REMAINING PORTION OF THE ONE YEAR ORIGINAL WARRANTY PERIOD. THE REPAIR OR REPLACEMENT OF DEFECTIVE PARTS UNDER THIS WARRANTY WILL BE MADE WITHOUT CHARGE TO THE OWNER EXCEPT FOR TRANSPORTATION.

KRAUSE DOES NOT WARRANT DISC BLADES, TIRES, CHISEL SHANKS, HYDRAULIC CYLINDERS, ACCESSORIES AND OTHER PARTS NOT MANUFACTURED BY IT BUT SUPPLIED WITH OR AS A PART OF ITS PRODUCTS. KRAUSE WILL, HOWEVER, OBTAIN AND PASS ON ANY ADJUSTMENTS PROVIDED BY THE MANUFACTURERS OF SUCH PARTS UNDER THESE MANUFACTURER'S WARRANTIES.

THE PROVISIONS OF THIS WARRANTY DO NOT APPLY TO ANY PRODUCT OR PARTS WHICH HAVE BEEN SUBJECT TO MISUSE, NEGLIGENCE OR ACCIDENT, OR WHICH HAVE BEEN REPAIRED OR ALTERED OUTSIDE OF KRAUSE'S FACTORY IN ANY WAY SO AS IN THE JUDGEMENT OF KRAUSE TO AFFECT ADVERSELY ITS PERFORMANCE OR RELIABILITY. NEITHER DOES THIS WARRANTY APPLY TO NORMAL MAINTENANCE SERVICE AND PARTS, OR TO NORMAL DETERIORATION DUE TO WEAR AND EXPOSURE.

TO THE EXTENT ALLOWED BY APPLICABLE LAW, THIS WARRANTY IS EXPRESSLY IN LIEU OF OTHER WARRANTIES, EXPRESSED OR IMPLIED, IN FACT OR BY LAW, INCLUDING ANY IMPLIED WARRANTY OF MERCHANTABILITY OR FITNESS FOR A PARTICULAR PURPOSE. THE REMEDIES OF REPAIR OR REPLACEMENT AS SET FORTH ARE THE ONLY REMEDIES UNDER THIS WARRANTY. KRAUSE DISCLAIMS ANY OBLIGATIONS OR LIABILITY FOR LOSS OF TIME, INCONVENIENCE, COMMERCIAL LOSS OR DIRECT, CONSEQUENTIAL, SPECIAL OR INCIDENTAL DAMAGES. THIS WARRANTY IS IN LIEU OF ANY OTHER OBLIGATION OR LIABILITY OF KRAUSE OF ANY NATURE WHATSOEVER BY REASON OF THE MANUFACTURE, SALE, LEASE OR USE OF SUCH PRODUCTS AND KRAUSE NEITHER ASSUMES, NOR AUTHORIZES ANYONE TO ASSUME FOR IT, ANY OTHER OBLIGATION OR LIABILITY IN CONNECTION WITH SUCH PRODUCTS.

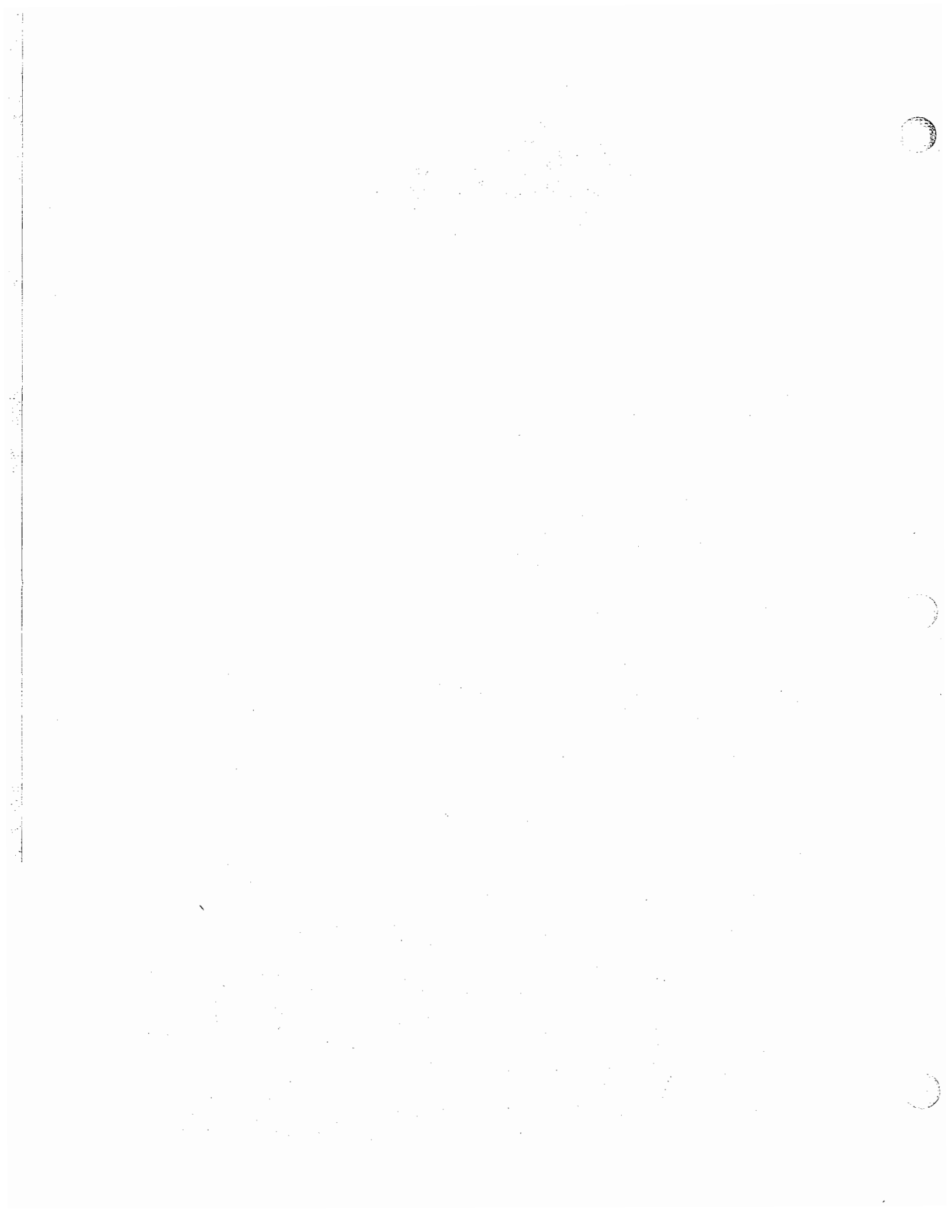

ASSEMBLY SECTION

THE FOLLOWING SECTION ILLUSTRATES A GENERAL METHOD FOR THE ASSEMBLY OF THIS SERIES KRAUSE TILLAGE TOOL. YOU MUST KNOW THE MODEL NUMBER OF THE UNIT BEING ASSEMBLED WHENEVER MAKING REFERENCE TO THIS SECTION. THE FOLLOWING PICTURES AND DRAWINGS WILL SHOW BOLTS, PINS, NUTS AND ETC., WITH THE DESCRIPTIVE SIZE AND LENGTHS IN THE ACCOMPANYING PARAGRAPH AND A PARTS LISTING REFERENCE PAGE NUMBER. IF ANY DIFFICULTY SHOULD BE ENCOUNTERED DURING THE ASSEMBLY, RECHECK THE ILLUSTRATIONS, ASSEMBLY STEPS AND PART LIST DRAWINGS.

PROPER BOLT USE

OVER TORQUED BOLTS is probably one of the most frequent causes for bolt breakages. MAXIMUM TIGHTNESS DOES NOT MEAN MAXIMUM STRENGTH. A bolt in a stretched condition due to over torsioning is more subject to failure under a heavy load or shock than a bolt that is correctly tightened. Torque hand wrench or torque adjustable impact wrenches should be used. If standard wrenches are used, try to refrain from using "cheater bars." Cheater bars increase the risk of over torsioning. When torqued properly, bolts and their joining members will give longer, more satisfying service.

The following table lists the torque requirements for bolts with coarse threads. Torque values for plated or oiled bolts are unpredictable due to the lubricating effect and require slightly less torque than black bolts.

RECOMMENDED TORQUE VALUES IN FOOT POUNDS

For S.A.E. Grade 2 and Grade 5 coarse thread cap screws and bolts shown are suggested MAXIMUM for fasteners, carrying only the residue oil of the manufacturer.

BOLT SIZE	BLACK BOLTS		PLATED or OILED BOLTS	
	GRADE 2	GRADE 5	GRADE 2	GRADE 5
3/8"	19	32	16	24
7/16"	30	50	24	40
1/2"	45	72	34	58
5/8"	86	150	68	118
3/4"	150	250	120	200
7/8"	140	360	105	280
1"	220	560	175	450
1-1/8"	260	700	205	560
1-1/4"	380	980	300	780
1-1/2"	580	1200	460	960

TIE ROD TIGHTENING TORQUE	
1-1/2" Dia. Rods _____	600 Ft. Lbs
1-3/4" Dia. Rods _____	800 Ft. Lbs
2" Dia. Rods _____	1200 Ft. Lbs

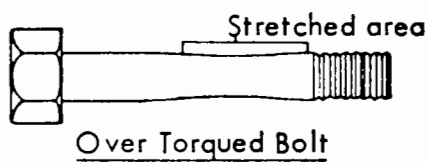

Incorrect use of GRADED bolts is another problem. Generally two grades are used on Krause tools, Grade 2 and Grade 5. Grade 2 bolts are used in low stress areas or for shear bolts to protect more expensive parts. Grade 5 bolts are approximately 60-150% stronger than Grade 2 and are used in higher stress areas. It is very important that these bolts are used in the proper locations as recommended

PARTS SECTION

THE FOLLOWING ILLUSTRATED PARTS SECTION HAS BEEN COMPILED TO REFLECT PART NUMBERS REQUIRED TO ORDER PARTS, AND TO SUPPORT THE ASSEMBLY SECTION FOR DIMENSIONS AND DESCRIPTIONS OF ALL PARTS, BOLTS, PINS, ETC. THE OPERATOR CAN ALSO IDENTIFY PART NAMES TO CLARIFY PROPER OPERATIONAL STEPS.







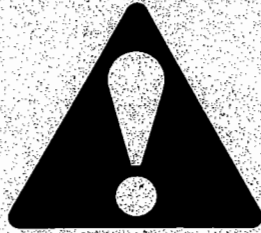

OPERATING SECTION

SAFETY ALERT SYMBOL

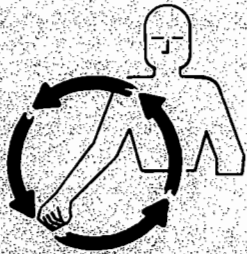
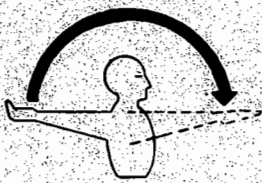

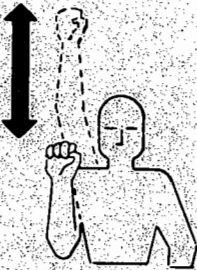
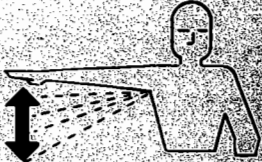
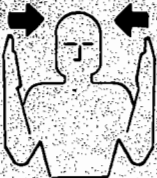
BE ALERT TO THE POSSIBILITY OF PERSONAL INJURY. THIS SYMBOL IDENTIFIES IMPORTANT SAFETY MESSAGES. CAREFULLY READ THE MESSAGE THAT FOLLOWS.

TEN MOST COMMON HAND SIGNALS USED IN THE FIELD

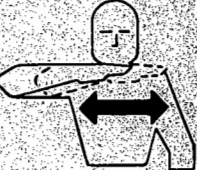
 <p>START THE ENGINE</p>	 <p>MOVE OUT OR TAKE OFF</p>	 <p>MOVE TOWARD ME</p>	 <p>SPEED IT UP</p>	 <p>SLOW IT DOWN</p>
 <p>THIS FAR TO GO</p>	 <p>STOP</p>	 <p>RAISE THE EQUIPMENT</p>	 <p>LOWER THE EQUIPMENT</p>	 <p>STOP THE ENGINE</p>

3900 SERIES TWO SECTION FIELD CULTIVATOR
DEALER PREDELIVERY CHECK
TO BE CHECKED BY DEALER

CUSTOMER _____ DATE _____

ADDRESS _____

DEALER _____

MODEL NUMBER _____ SERIAL NUMBER _____

DEALER CHECK:

1. ___ Check to see that all rocker shaft bolts are tight and pins are in place.
2. ___ Check to see that hydraulic cylinders are full of oil (air bled out of cylinders). Clevis pins with hair pin clips should be in place. Hydraulic system requires 10.5 Quarts / 10 Liters of oil.
3. ___ Examine hydraulic hoses to see that they are protected from damage.
4. ___ Check lug bolts holding wheels to the hub to see that they are torqued from 90 to 95 Ft. Lbs. / 120 N · m.
5. ___ The correct size tire, 10:00 X 15, 8-Ply with 36 PSI / 248 kPa pressure, should be on the implement.
6. ___ Check to see that bolts attaching hitch to frame and clevis weldment to hitch are in place and tightened.
7. ___ Jack should be operational for support of tongue when implement is not attached to a tractor.
8. ___ Wing is attached with special pins and secured with self locking nuts.
9. ___ Road lock and wing lock was correctly installed and operates satisfactorily.
10. ___ Restrictor is installed in wing lift cylinder rod end port.
11. ___ All decals are in place per page A13 of this owner's manual.
12. ___ Customer review sheet is filled out and signed.

DELIVERED BY _____

DATE _____

3900 SERIES TWO SECTION FIELD CULTIVATOR
CUSTOMER REVIEW SHEET

CUSTOMER _____ DATE _____

ADDRESS _____

DEALER _____

MODEL NUMBER _____ SERIAL NUMBER _____

1. ___ Owner's manual provided.
2. ___ Warranty card filled out and mailed.
3. ___ Review safety warnings and cautions as listed in this owner's manual.
4. ___ Review recommended maximum road speed, width, and height for implement.
5. ___ Review field operational speeds, horsepower, depth, and rock conditions.
6. ___ Demonstrate the proper use of road lock.
7. ___ Explain the hydraulic depth control system.
8. ___ Review limitations of additional weight and transport speed when adding attachments.
9. ___ Explain the importance of maintaining the tools through lubrication, checking that bolts are kept tight, and replacement of worn or broken parts.
10. ___ Recommend that a safety chain be used with the tool.
11. ___ Check wheel lug bolts frequently until they become set.

DEALER _____ DATE _____

CUSTOMER _____ DATE _____

CONTENTS

WARRANTY		WING FRAME & SUPPORT	P6
DEALER PREDELIVERY CHECK SHEET		HUB ASSEMBLY	P7
CUSTOMER REVIEW SHEET		WHEEL & TIRE ASSEMBLY	P8
TABLE OF CONTENTS	1	SPRING SHANK ASSEMBLY	P10
SPECIFICATIONS	2	HINGE & EXTENSION	P11
HYDRAULICS AND TIRE INFORMATION	3	SHANK EXTENSION WELDMENTS	P12
GENERAL INFORMATION DRAWING	4	HYDRAULIC HOSE & PARTS	P14
GENERAL INFORMATION PHOTOGRAPH	5	HYDRAULIC CYLINDERS:	
TRANSPORT PHOTOGRAPH	6	Prince 4" X 8" (Rephasing Master)	P15
<u>OPERATING SECTION</u>		Prince 3-3/4" X 8" (Slave)	P16
SAFETY FIRST	01	Prince 4" X 32" (Wing Lift)	P17
ABOUT YOUR FIELD CULTIVATOR	02	DECAL & REFLECTOR PLACEMENT	P18
UNDERSTANDING YOUR HYDRAULIC		<u>ASSEMBLY SECTION</u>	
DEPTH SYSTEM	02	SAFETY	A1
PREPARING THE FIELD CULTIVATOR		ASSEMBLY	A1
FOR OPERATION	03	PART LOCATIONS	A1
PREPARING THE TRACTOR	03	ASSEMBLY STEPS	A1
HYDRAULIC SYSTEM	04	MODEL NUMBER	A2
HITCHING & UNHITCHING	04	Step 1 Frame	A2
Hitching To The Tractor	05	Step 2 Rocker Shaft	A3
Unhitching From The Tractor	05	Step 3 Wheel Hubs-(Main Frame)	A4
TRANSPORTING	06	Step 4 Hydraulic Cylinder &	
Road Lock	06	Road Lock-(Main Frame)	A4
Raising The Wing	06	Step 5 Tongue Jack & Hose	
Lowering The Wing	07	Carrier	A5
Transport Safety	07	Step 6 Free Standing Center	
Hitch Pin	08	Section & Frame	
FIELD ADJUSTMENTS		Step 7 Shank Extensions -	A5
Leveling The Frames	09	(Main Frame)	A6
Flexibility	010	Step 8 Wing Frame to Main	
Controlled Depth	011	Section	A6
Turning In The Field	011	Step 9 Hitch Assembly	A7
Field Speed	011	Step 10 Wing Rocker Shaft	A7
Folding Extensions	011	Step 11 Wing Wheel & Hydraulic	
GENERAL INFORMATION	012	Cylinder	A8
Your Field Cultivator Having		Step 12 Wing Lock & Wing Rest	A8
Field Problems?	012	Step 13 Wing Lift Brackets	A9
SERVICING		Step 14 Shank Extensions	A9
General Maintenance	012	Step 15 Hydraulics	A10
Lubrication	013	Step 16 Filling Cylinders	
Wheel Bearings	013	With Oil	A10
HYDRAULIC SAFETY	013	Depth Control	A10
Storage	014	Wing Lift	A11
Repair Parts	014	Step 17 Shank Assembly	A12
SUGGESTED REMEDIES FOR POSSIBLE		Step 18 Points	A12
FIELD PROBLEMS	015-018	Step 19 Lamp Bracket	A13
		Step 20 Decal & Reflectors	A13
<u>PARTS SECTION</u>		<u>PLACEMENT DRAWINGS</u>	
MAIN FRAME	P2	SHANK LOCATIONS	A14
ROCKER SHAFTS	P4	CORRECT SHANK EXTENSION	
		LOCATIONS	A15

SPECIFICATIONS

MODEL	CUT WIDTH		SHANK SPACING (INCHES)	NUMBER OF SHANKS	TRANSPORT			
	FEET	METRES			WIDTH	HEIGHT	FEET	METRE
3940 BASIC	18'8"	5.7	7	32	12'0"	3.6	11'7"	3.5
3940 + 2	19'10"	6	7	34	12'0"	3.6	11'7"	3.5
3940 + 4	21'0"	6.4	7	36	12'4"	3.7	11'8"	3.5
3940 + 6	22'2"	6.7	7	38	13'0"	3.9	12'2"	3.7
3940 + 8 RIGID	23'4"	7.1	7	40	13'6"	4.1	12'8"	3.8
3940 + 8 FOLDING	23'4"	7.1	7	40	12'4"	3.7	11'7"	3.5
3940 + 10 FOLDING	24'6"	7.5	7	42	12'4"	3.7	11'7"	3.5
3940 + 12 FOLDING	25'8"	7.8	7	44	13'0"	3.9	12'2"	3.7

ADDITION OF TINE OR SPIKE HARROWS MAY INCREASE
OVERALL TRANSPORT WIDTH AND HEIGHT.

WHEEL TREAD ALL MODELS

MAIN SECTION --- 124-1/2 INCHES

WING SECTION TO CENTER WHEEL --- 92-1/2"

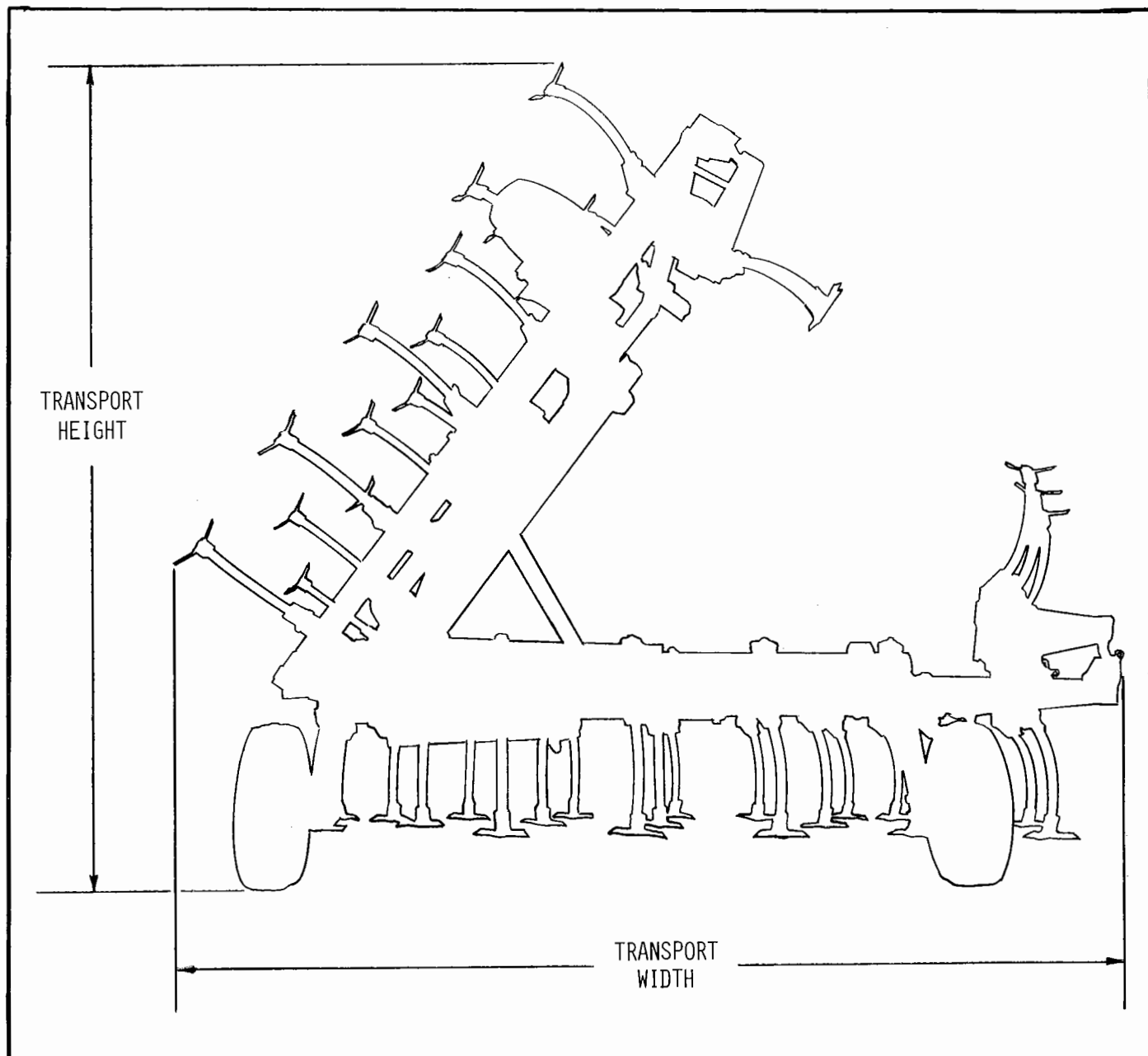

HYDRAULICS

DEPTH CONTROL	- 4 X 8 CYLINDER (For Center)	28-1/4" Open / 20-1/4" Closed
	3-3/4 X 8 CYLINDER (For Wing)	28-1/4" Open / 20-1/4" Closed
WING LIFT	- 4 X 32 CYLINDER	74-3/4" Open / 42-3/4" Closed
	WITH SPRING TRUNNION ASSEMBLY	76-3/4" Open / 44-3/4" Closed

TIRES

10:00 X 15 -- 8 PLY -- LOAD LIMIT 3,450 AT 36 P.S.I.

TWO TIRES IN MAIN SECTION SHOULD HAVE A
3,000 POUND LOAD RATING OR BETTER

GENERAL INFORMATION

11/82

FOR YOUR SAFETY:

ALWAYS PIN TRACTOR DRAWBAR BEFORE TRANSPORTING. USE A SAFETY CHAIN WITH THE TENSILE STRENGTH EQUAL TO THE GROSS WEIGHT OF THE LOAD BEING TOWED.

ROAD AT A REASONABLE SPEED DO NOT EXCEED 20 M.P.H.

CHECK THESE POINTS PERIODICALLY FOR WEAR.

I M P O R T A N T
GREASE LOCATIONS

THE WING LOCK PIN SHOULD ALWAYS BE ENGAGED WHEN THE WING IS IN THE RAISED POSITION. STORE THE PIN IN THE HOLE PROVIDED IN THE WING LIFT STRAP.

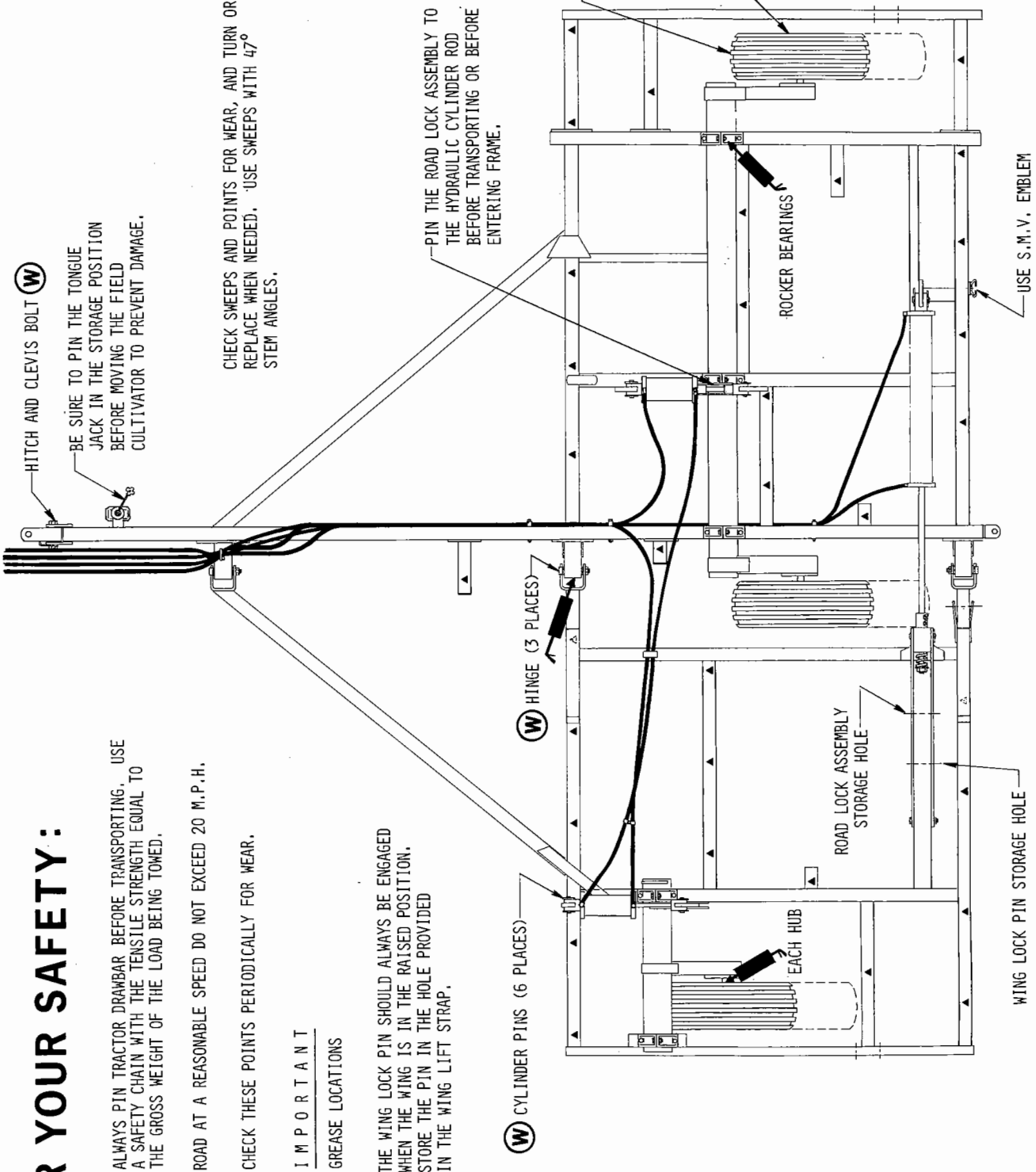

W HITCH AND CLEVIS BOLT

BE SURE TO PIN THE TONGUE JACK IN THE STORAGE POSITION BEFORE MOVING THE FIELD CULTIVATOR TO PREVENT DAMAGE.

CHECK SWEEPS AND POINTS FOR WEAR, AND TURN OR REPLACE WHEN NEEDED. USE SWEEPS WITH 47° STEM ANGLES.

PIN THE ROAD LOCK ASSEMBLY TO THE HYDRAULIC CYLINDER ROD BEFORE TRANSPORTING OR BEFORE ENTERING FRAME.

W CYLINDER PINS (6 PLACES)

W HINGE (3 PLACES)

CHECK TIRE PRESSURE BEFORE OPERATION, 10.00 X 15, 8-PLY AT 36 P.S.I.

TORQUE WHEEL BOLTS 90 TO 95 FT. LBS. CHECK FREQUENTLY UNTIL FIRMLY SEATED.

ROCKER BEARINGS

ROAD LOCK ASSEMBLY STORAGE HOLE

EACH HUB

WING LOCK PIN STORAGE HOLE

USE S.M.V. EMBLEM

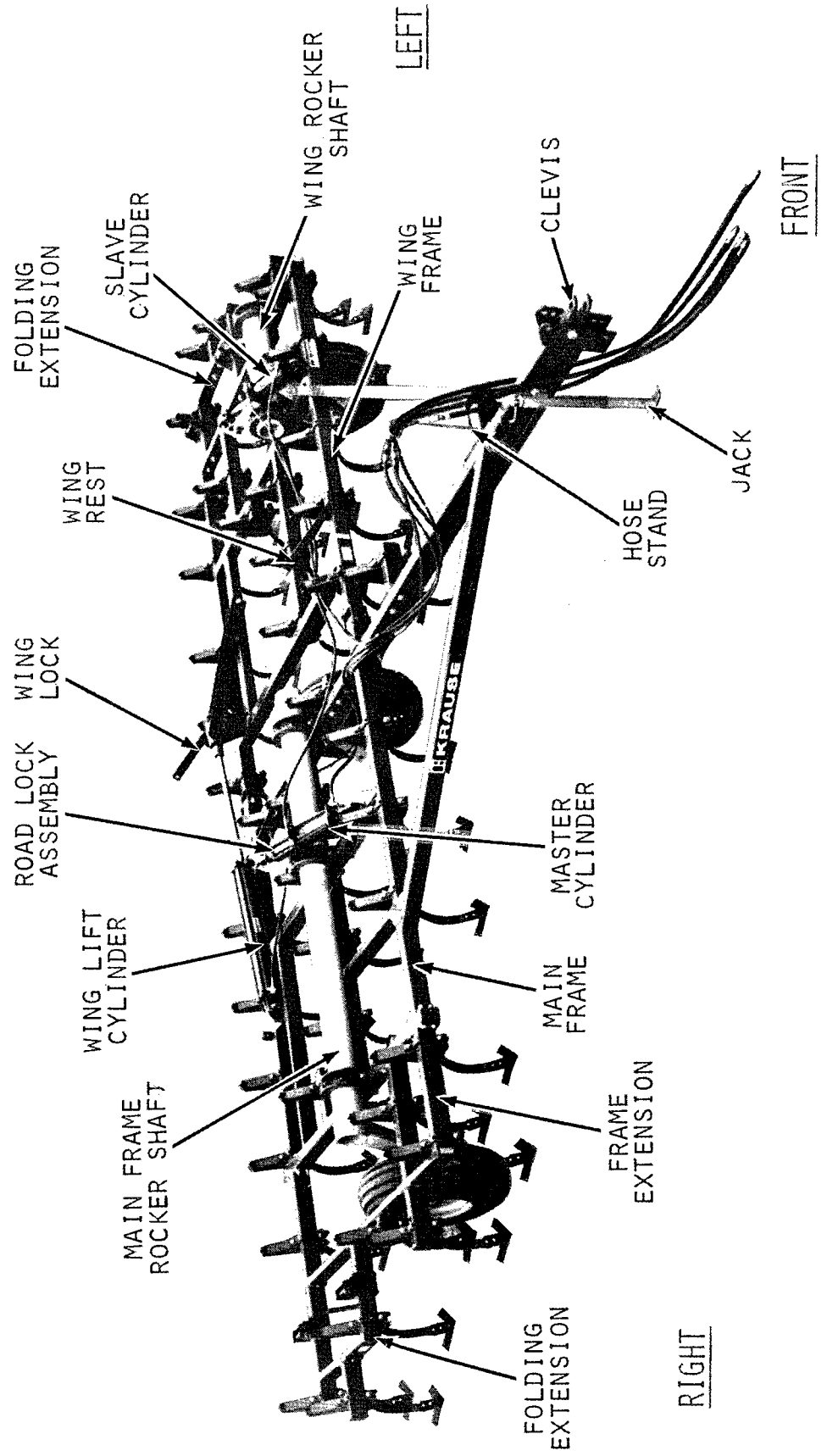

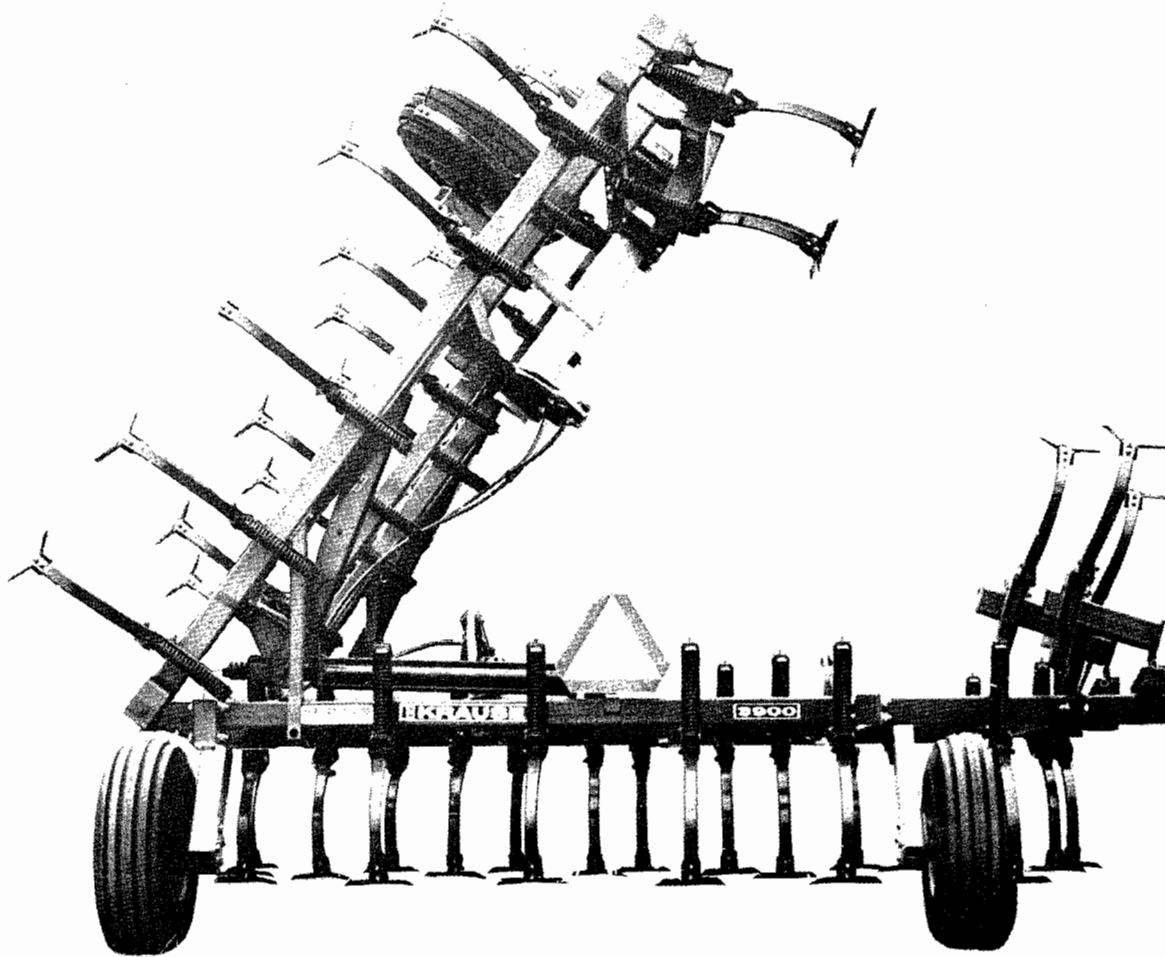

OPERATING INSTRUCTIONS



READ ALL THE SAFETY DECALS ON THE FIELD CULTIVATOR AND REVIEW THE SAFETY FIRST SUGGESTIONS ON THE BACK COVER OF THE MANUAL TO REFRESH YOUR MEMORY. WATCH FOR THE SAFETY SYMBOL AND READ THE INFORMATION. THIS IS FOR YOUR OWN PROTECTION.

ABOUT YOUR FIELD CULTIVATOR

This field cultivator has been designed for secondary tillage and is flexible enough to follow the contours of most field conditions.

It is designed to be used for control of weeds, volunteer plants, erosion control, chemical incorporation, and seed bed preparation. The field cultivator works best at speeds of 5 to 6-1/2 M.P.H., however, rocky conditions may require a slower field speed.



Horsepower requirements generally will be 2.5 drawbar horsepower, or 3.25 engine horsepower per shank. For additional information, request a "Tillage Implement Width Calculator" from your dealer.

Adding attachments should be limited to KRAUSE original equipment options, or light duty tine or spike harrows that weigh no more than 35 pounds per foot of cut. Additions of harrows may make the field cultivator "tail heavy" and the rear jack mount part number 4122-28-0 should be ordered.

UNDERSTANDING YOUR HYDRAULIC DEPTH CONTROL SYSTEM

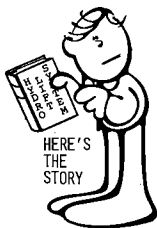

The 3900 Series Field Cultivator uses a master and slave system of depth control cylinders.

As oil is pumped into the base of the master cylinder, oil is forced out of the ram end and into the base end of its slave cylinder. In turn, this forces oil out of the slave cylinder which then returns to the tractor hydraulic reservoir.

Since there is a smaller volume of oil which passes from the ram end of the master cylinder to the base end of the slave cylinder, the cylinders must be progressively smaller in diameter. In this system, the master cylinder is 4" diameter, and the slave cylinder is 3-3/4" diameter. Both have an 8" stroke.

When the cultivator is raised completely out of the ground, these specially designed cylinders are synchronized for uniform lifting by holding the tractor remote hydraulic control lever in the raised position for a few seconds. This allows a small volume of oil to bypass from the base of the master cylinders to the base of the slave cylinders, and back to the tractor. Consequently, all of the cylinders are fully extended simultaneously.

SAFETY FIRST



WATCH FOR THIS SYMBOL AND CAREFULLY READ THE MESSAGE.

1. Read and understand this owner's manual before operating the machine.
2. Be sure safety decals and reflectors are clean and in place.
3. Lower implement to the ground before entering frame to make adjustments.
4. Never position yourself under any portion of implement unless the transport locks are engaged or entire unit is lowered to the ground.
5. Stop engine and set parking brake before leaving operator's position to adjust, lubricate, clean or unclog the machine.
6. Do not allow any person to stand between the tractor and field cultivator while backing into position. Sudden loss of control could cause serious injury or death to a person caught between the tractor and implement.
7. Do not stand on or straddle a tongue when hitching.
8. Always store this implement with the wing down.
9. Never operate this unit until hydraulic cylinders and lines are full of oil and free of air. See Operating Instructions.
10. Use a (SMV) Slow-Moving-Vehicle emblem when roading.
11. Always use a safety chain of tensile strength equal to the gross weight of the implement and attachments when roading.
12. Check wheel bolts before transporting and after the first 1/2 mile of initial transport (delivery). If loose, tighten to 90 to 95 Ft. Lbs. torque. Continue to check frequently until wheel bolts remain firmly seated.
13. Always use wing lock and road lock to hold raised position.
14. Do not road an implement over 15 miles per hour on the best surface conditions. Reduce speed when going up or down hills and approaching ditches or corners.

HITCHING TO THE TRACTOR

1. The field cultivator must be in a raised position and transport road lock in place before hitching to the tractor. The clevis spring will hold the clevis forward.

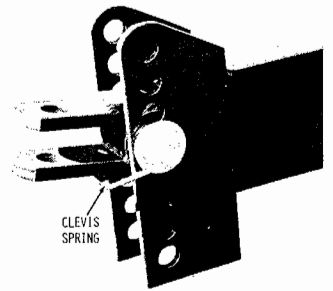

2. Unpin the tractor drawbar so it can be moved from side to side.

3. Back the tractor to the field cultivator.

4. Attach the clevis ① to tractor drawbar ② with clevis pin ③ that fits the hole size in the tractor drawbar. Make sure the pin is locked or bolted ④ in place to prevent loss.

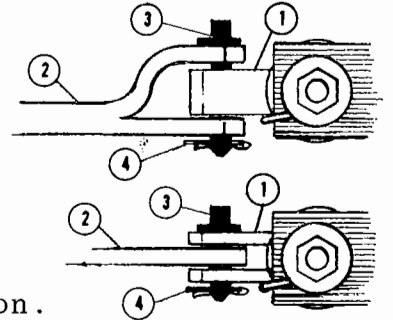

5. Place tongue jack in storage position.

6. Connect hydraulic hoses to tractor. DO NOT OPERATE HYDRAULICS UNTIL YOU HAVE READ "RAISING THE WING", on page O6.

UNHITCHING FROM THE TRACTOR

If the field cultivator is not to be used for the remainder of the day, select a good parking place that will permit the lowering of the wing. The field cultivator should be parked in the storage position with the wing down and road lock in place. If the field cultivator is to remain parked for storage over a long period of time, be sure to read storage suggestions on page O14.

1. To unhitch the tractor from the field cultivator, place the tractor in park or neutral and set the hand brake. If you are not parking on level ground the field cultivator will require the tires to be blocked.

2. Have all personnel stand clear and lower the wing.

3. Turn off the tractor engine and relieve any pressure that might be in the implement hydraulic system by moving the tractor control lever(s) back and forth.

4. Lower tongue jack and raise the tongue height until clevis pin is loose and remove pin.

5. Disconnect the hydraulic hoses and the tractor may be moved away.

 **CAUTION:** DO NOT STAND ON OR STRADDLE A TONGUE WHEN UNHITCHING. IF ATTACHMENTS HAVE BEEN ADDED TO REAR OF UNIT, IT MAY AFFECT THE BALANCE OF THE IMPLEMENT, CAUSING THE TONGUE TO COME UP SUDDENLY WHEN UNHITCHING.

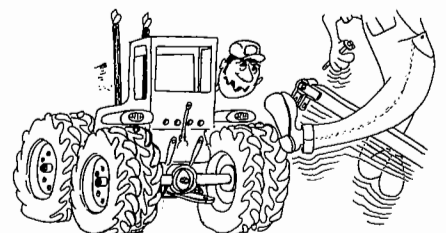

TRANSPORTING

Check specification pages and be aware of transport height and width of your model of field cultivator.

! WARNING: ALWAYS USE TRANSPORT ROAD LOCKS WHEN TRANSPORTING IMPLEMENTS TO PREVENT UNIT FROM FALLING DUE TO HYDRAULIC FAILURE, OR ACCIDENTAL ACTIVATION OF THE OPERATOR'S CONTROL. LOWERING OF TOOL DURING TRANSPORTING COULD RESULT IN LOSS OF CONTROL OF IMPLEMENT AND/OR TRACTOR. THE TRACTOR DRAWBAR MUST ALWAYS BE PINNED FOR TRANSPORT.

ROAD LOCKS

Place the road lock assembly over the hydraulic cylinder shaft at the center rocker shaft location, secure with pin and flat washer. NOTE: Stroke control rings may be left in place on the cylinder shaft. See Figure 1 below. Store road lock assembly over support bar on the wing lift weldment as shown in Figure 2 below.



Figure 1



Figure 2

IMPORTANT: NEVER RETRACT DEPTH CONTROL CYLINDER OR EXTEND WING LIFT CYLINDER UNTIL LOCK PIN HAS BEEN DISENGAGED, OR DAMAGE WILL OCCUR TO THE FRAME, OR HYDRAULIC CYLINDER.

RAISING THE WING

! WARNING: ALWAYS STAND CLEAR OF WING WHEN IT IS IN THE RAISED POSITION. A HYDRAULIC FAILURE OR ACTIVATION OF HYDRAULIC CONTROLS BY SOMEONE COULD RESULT IN SERIOUS INJURY TO ANYONE UNDER THE WING.

When working with this kind of arrangement, be sure the cylinders are mounted in proper sequence. Hoses must be attached in the proper order, and all air bled from the hoses and cylinders. See page 04 under "HYDRAULICS" for synchronizing instructions.

PREPARING THE FIELD CULTIVATOR FOR OPERATION



1. The wing should be down, and the road lock engaged. The tongue jack supporting the tongue, and the hydraulic cylinders pinned and full of oil.
2. The wing lock pin should be stored in its storage hole and not in the clevis locking ends.
3. Check for loose bolts and tighten if needed. Check again for loose bolts after the first half day of operation.
4. Check the shank locations with the Placement Diagram at the back of this book for the size being used to be sure the unit has been set up properly.
5. Check tire pressure. Inflate 10:00 X 15, 8-Ply tires to 36 P.S.I. Also check the wheel lug bolts to see if they are torqued to 90 to 95 FT. LBS., and that wheel hub bearings do not have excessive end play.
6. Make sure that all grease zerks locations have been sufficiently greased. Grease zerks will be found on the rocker shaft bearings, and wing hinges. USE EXTREME CAUTION WHEN WORKING AROUND SHARP SHANK POINTS.
7. Check and adjust tightness of wheel bearings before operation, after the first week, and periodically thereafter. See Service Section of this book.



CAUTION:

CHECK TO SEE THAT THE WHEEL LUG BOLTS ARE TORQUED 90 TO 95 FT, LBS, THE BOLTS MAY WORK LOOSE, RESULTING IN THE LOSS OF A WHEEL AND SUBSEQUENT LOSS OF CONTROL OF THE TOOL AND/OR TRACTOR. CHECK AGAIN AFTER THE FIRST 1/2 MILE OF INITIAL TRANSPORT.

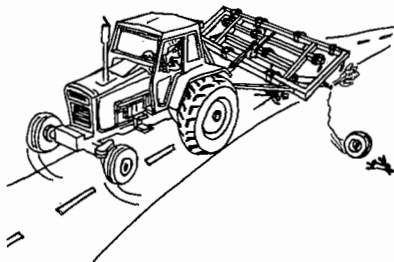

PREPARING THE TRACTOR

Read your tractor owner's manual. It will describe safe methods of operation. Make sure your tractor has proper added ballast, and that its hydraulic system is full of oil and working properly. Check tractor brakes and warning lights, make sure they are in working order.

HYDRAULIC SYSTEM

If the implement hydraulic system has never been used, stored over a period of time or disassembled for any reason, unpin the rod ends of all cylinders and support the cylinders so the rod ends will clear frame members or lugs when fully extended. Back the tractor to the front of the implement and connect the hydraulic hoses to the tractor. Check the tractor hydraulic reservoir and make sure it is full of the manufacturer's recommended oil. If not previously filled, your hydraulic system will require approximately 10.5 Quarts / 10 Liters of your tractor manufacturer's recommended oil. If you are sure the implement hydraulic hose connections are tight, begin filling the system by extending and retracting the cylinders. Hold the control lever open and pause at the end of each stroke of the cycles to bleed the air from the system. Continue the cycles until the cylinders respond with immediate solid actuation. When you are sure the systems are free of air, pin the rod ends of the cylinders to the implement cylinder lugs. After the system is filled inspect for leaks.



IMPORTANT: IF USING TAPE TYPE SEALERS, START THE TAPE ONE OR TWO THREADS FROM THE END OF THE FITTING TO PREVENT SHREDS OF TAPE FROM ENTERING THE SYSTEM AND PLUGGING THE HYDRAULIC OIL FILTERS. WRAP THE TAPE IN A CLOCKWISE DIRECTION USING APPROXIMATELY 5" OF TAPE PER FITTING, AND MAKING TWO COMPLETE WRAPS.



WARNING:

HIGH PRESSURE FLUID FLOW CAN PENETRATE SKIN. IF INJURED BY ESCAPING HYDRAULIC FLUID, SEE A DOCTOR AT ONCE. SERIOUS INJURY OR REACTION CAN DEVELOP IF PROPER TREATMENT IS NOT ADMINISTERED IMMEDIATELY.

BEFORE REMOVING ANY HYDRAULIC PARTS, ALWAYS RELIEVE HYDRAULIC PRESSURE IN THE SYSTEM.



WARNING:

AIR IN HYDRAULIC SYSTEM COULD ALLOW FIELD CULTIVATOR OR WING TO DROP SUDDENLY. STAND CLEAR. DO NOT STAND UNDER PARTIALLY RAISED WING.

A Hydraulic Hose and Cylinder layout can be found on P13 of the Parts Section.

HITCHING & UNHITCHING



DANGER:

DO NOT ALLOW ANY PERSON TO STAND BETWEEN THE TRACTOR AND FIELD CULTIVATOR WHILE BACKING INTO POSITION. SUDDEN LOSS OF CONTROL COULD CAUSE SERIOUS INJURY OR DEATH TO A PERSON CAUGHT BETWEEN THE TRACTOR AND IMPLEMENT. TELL YOUR HELPER TO WAIT UNTIL YOU GIVE HIM THE SIGNAL THAT THE TRACTOR IS IN PARK OR NEUTRAL AND THE HAND BRAKE IS SET AND THE ENGINE SHUT OFF.

The field cultivator should be in the raised position with road lock pin engaged. If the system is full of oil, you are ready to raise the wing. The wing will be secured in the raised position with the lock pin when the wing lock clevis comes to rest over the rear frame member. A storage hole is provided in the wing lift weldment for the wing lock pin. Be sure the wing lock pin is in this storage hole before lifting the wing or damage to the frame may occur.

LOWERING THE WING

Retract the wing lift cylinder to its minimum stroke. Remove wing lock pin and place in storage hole. Lower wing with all persons standing clear.

Place wing lock pin in storage hole before lowering the wing.

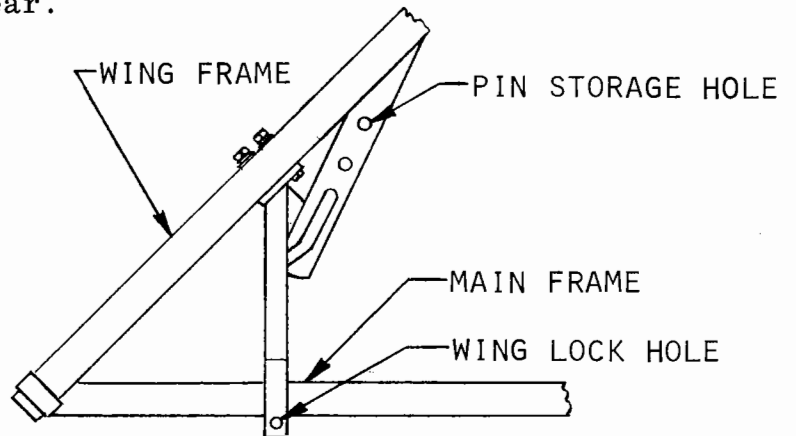

TRANSPORT SAFETY

WARNING: WHEN TRANSPORTING, ALWAYS USE A SAFETY CHAIN WITH TENSILE STRENGTH EQUAL TO THE GROSS WEIGHT OF THE UNIT, PLUS ANY ATTACHMENTS.

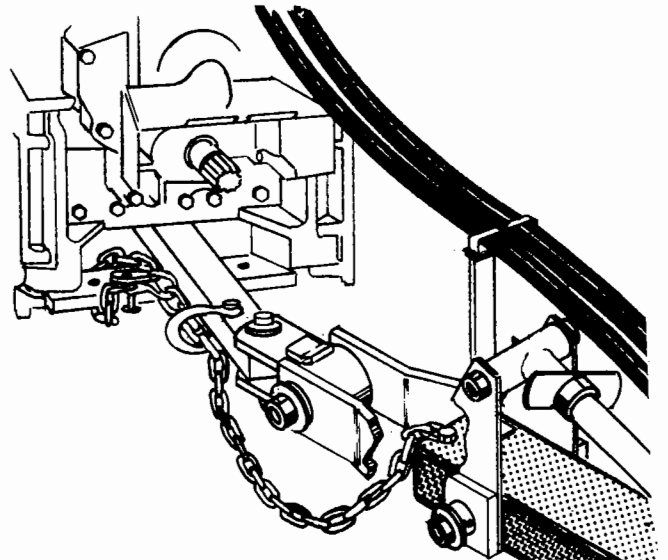

CAUTION: ALWAYS CHECK CONDITIONS OF WING LOCK PIN, ROAD LOCK ASSEMBLIES, TIRES, WHEELS, HUBS, SAFETY CHAIN, HITCH BOLTS, AND CLEVIS PIN BEFORE TRANSPORTING THE FIELD CULTIVATOR. PIN YOUR TRACTOR DRAWBAR BEFORE TRANSPORT.

Use the ASAE Slow-Moving-Vehicle (SMV) emblem. The emblem is to be mounted, point up, in a plane perpendicular to the direction of travel ± 10 degrees. It shall be placed centrally at the rear of the vehicle, unobscured, and 2' to 6' (0.61 to 1.8m) above the ground, measured from the lower edge of the emblem. The SMV emblem should be wiped clean before entering the road or highway.

Comply with state and local laws pertaining to lighting and road widths. Transport during daylight hours only. Watch your clearance. Be aware of obstacles on the side of the road that might be caught by the field cultivator. Pull over to the side of the road to permit safe clearance for oncoming vehicles. Keep the red and yellow reflectors clean and visible. Replace the reflectors if they become faded or damaged. Watch for narrow bridges and re-route if necessary. Watch for pedestrians on the side of the roadway that need to be warned of your presence.



Be aware of the transport height as well as the width of your size of field cultivator. Care should be taken not to snag low hanging telephone lines or electrical service lines.

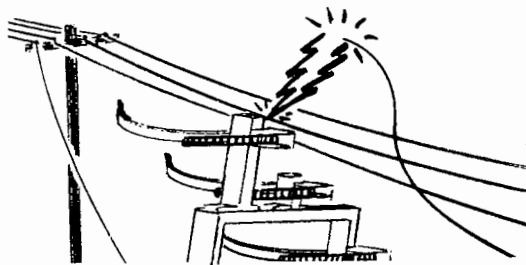

WARNING: MEASURE OVERALL TRANSPORT HEIGHT. TINE OR SPIKE HARROWS MAY ADD TO THE TRANSPORT HEIGHT.

It is best to use a tractor to transport the field cultivator to another location. If using another type of towing unit it should never be allowed to exceed 15 M.P.H., since implement tires are not constructed to operate at higher speeds. The towing vehicle should always equal or exceed the gross weight of the field cultivator and attachments.

Always check the tire pressure before transporting and look for damaged tires. Wobble the tires from side to side. If excessive play is noted, adjust the hub spindle nut before roading to prevent damage to the hub or bearings.

CAUTION: IT IS VERY IMPORTANT TO CHECK WHEEL LUG BOLTS AFTER THE FIRST 1/2 MILE OF INITIAL TRANSPORT (DELIVERY). IF LOOSE, TIGHTEN TO 90 TO 95 FT. LBS. TORQUE. CONTINUE TO CHECK FREQUENTLY UNTIL THEY REMAIN FIRMLY SEATED.

HITCH PIN

Use the proper size hitch pin with a means for holding it in place so it cannot work itself out during transport. The hitch pin should be inspected for wear or cracks before using it to transport your field cultivator.

FIELD ADJUSTMENTS

LEVELING THE FRAMES

To operate your field cultivator most efficiently, it must be worked level. This is best accomplished when starting to work in the field to be cultivated, following the steps listed below.

Step 1. Fully extend wing lift hydraulic cylinder so the wing is free to follow the contour of the land.

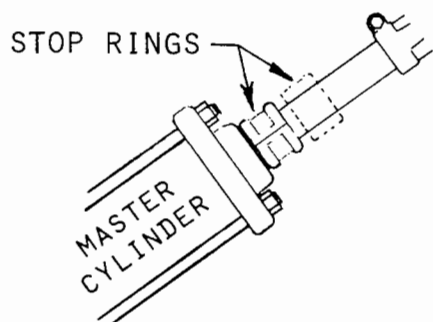

Lower the field cultivator to the approximate depth desired. Stop the tractor with the cultivator still in the ground. Position the depth control rings on your 4 X 8 hydraulic cylinder rod so the wheels will lower to the same position each time.

Step 2. After the depth control has been set, and before moving the field cultivator, stand at one side of the field cultivator at a reasonable distance and view the frame from front to back. If the frame is not level, adjust the hitch clevis up or down to a level location. This is accomplished by removing BOLT A, and moving hitch to desired location. The jack will aid in making this adjustment.

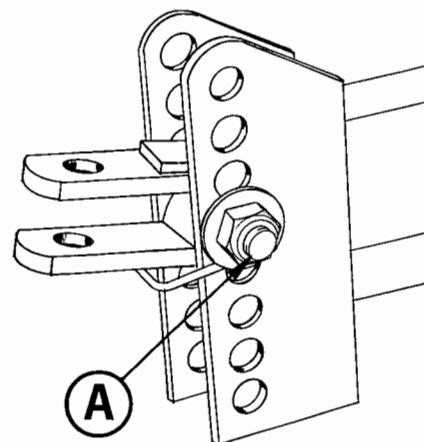

Pull the field cultivator forward a few feet, dismount from the tractor and recheck to be sure the unit is now level from front to back.

Step 3. Before moving the field cultivator, check the frames for side to side leveling, while viewing from the back.

An adjustment for wing leveling is provided on the wing rocker shaft cylinder lug. To RAISE wing loosen Bolt "A" and move UP in slot. To LOWER move Bolt "A" DOWN in the slot.

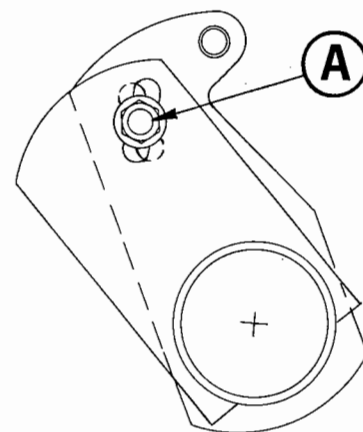

WING ROCKER SHAFT 

Additional adjustments can be made by rotating wheel hub locations on wheel arms.

The wing or left section may not be level with the center section frame when the field cultivator is in the raised position.

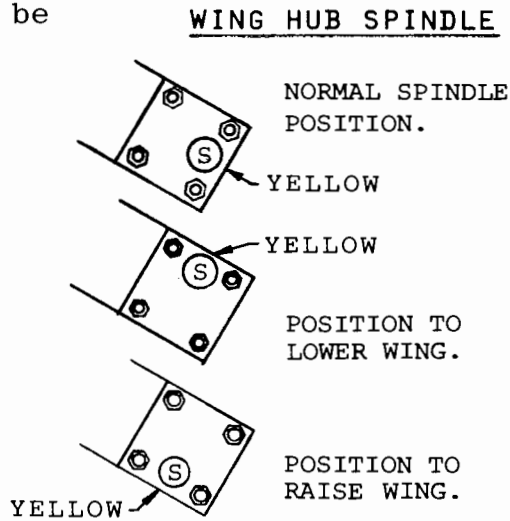

FLEXIBILITY

For maximum flexibility, make sure the wing hydraulic cylinder is fully extended after the wing is down.

When working terraced ground, place the wing up on the terrace, not down over the terrace, as the wing is limited in its downward movement, but not in its upward movement.

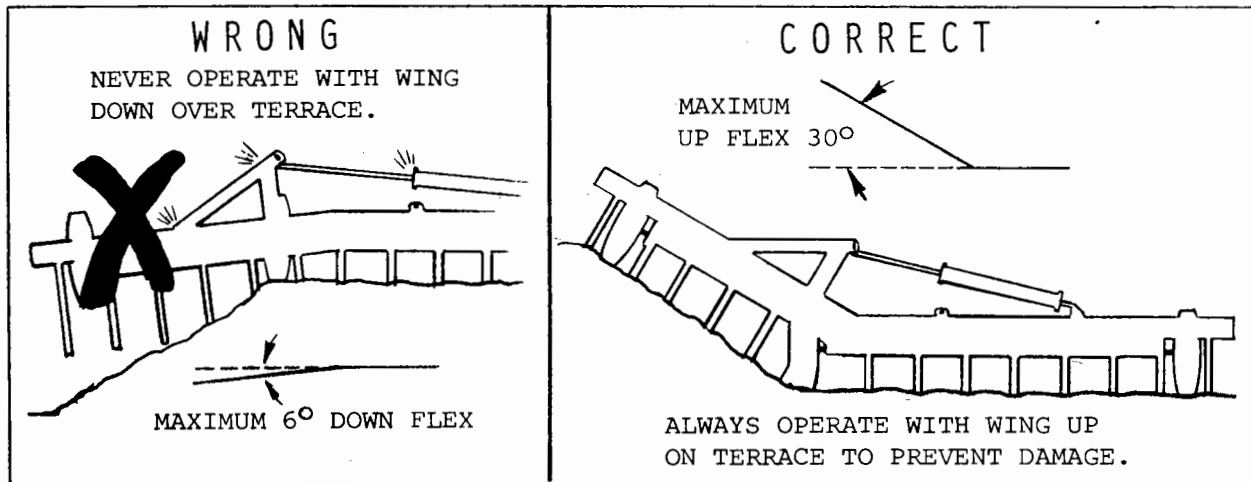

Sometimes in hard soil conditions the field cultivator will buckle or raise up in the center. The spring trunnion on the rod end of the wing lift cylinder will resist this action. If cultivator continues to buckle, tighten nut at end of the spring (A); if necessary use washers under the nut.

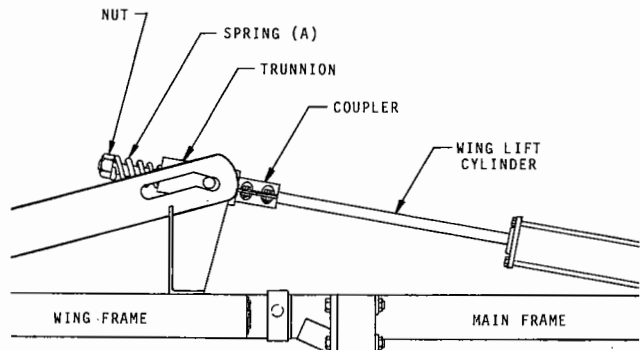

CONTROLLED DEPTH

When working hard soil it may be necessary to go over the ground more than once to obtain the desired depth. DO NOT REMOVE SHANKS in an effort to pull faster or deeper since this will cause the remaining shanks and mountings to be over loaded.

After determining the correct depth, position the depth control rings on your hydraulic cylinder rods so the wheels will lower the frames and shanks to the same position each time.

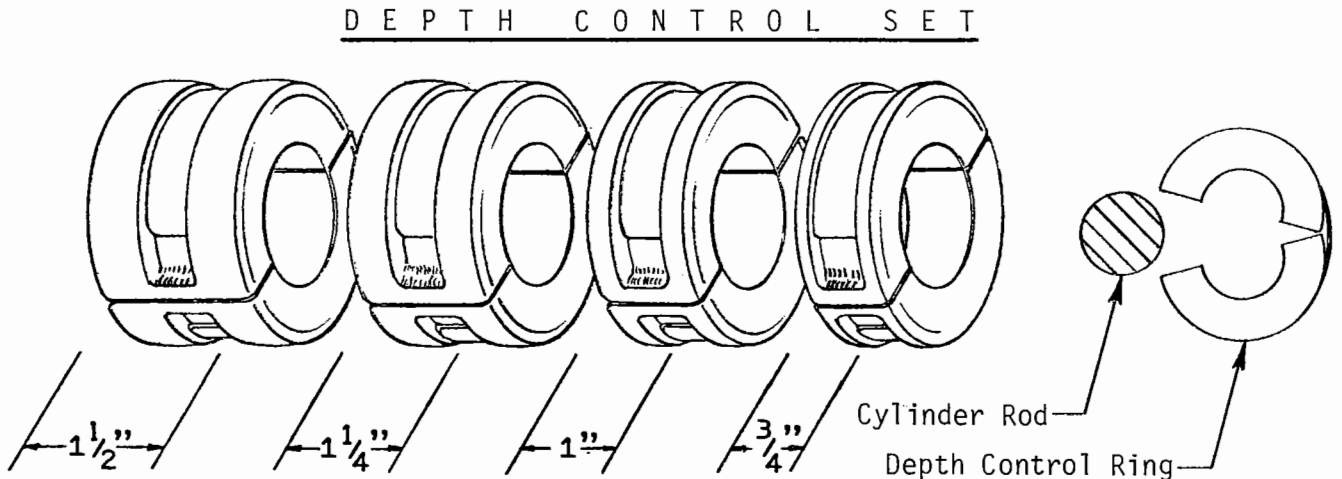

⚠ WARNING: LOWER IMPLEMENT TO THE GROUND BEFORE ENTERING FRAME TO MAKE ADJUSTMENTS.

TURNING IN THE FIELD

Short turns at working depth may result in driving the outside shanks deeper in the ground, causing damage to shanks or frame members. If short turns must be executed, raise the cultivator out of the ground and complete the turn before engaging the tool for further tilling.

IMPORTANT: 4-WHEEL DRIVE TRACTORS CAUSE SEVERE SIDE STRAIN ON TONGUE AND CLEVIS UNLESS THE DRAWBAR IS FREE TO SWING. ALWAYS ALLOW DRAWBAR TO SWING DURING FIELD OPERATION. DRAWBAR MUST BE PINNED FOR TRANSPORT.

FIELD SPEED

While high field speeds of around 6-1/2 M.P.H. may be recommended for weed killing purposes in light soils and shallow depth, a slower speed is recommended for heavy soils, deep work or rocky conditions. Slower speed will add life to field cultivator points and sweeps.

FOLDING EXTENSIONS

DO NOT WORK YOUR FIELD CULTIVATOR WITH THE EXTENSIONS LEFT IN THE FOLDED POSITION. When the unit is lowered into the ground, the tires will come up and strike the extensions and damage the tires.

GENERAL INFORMATION

Points are recommended for light soils and when higher ridges are desired. Sweeps are for light draft cultivation and not for deep work. KRAUSE field cultivator shanks require 47° stem angle sweeps. Sweeps up to 9" wide can be used.

POINT

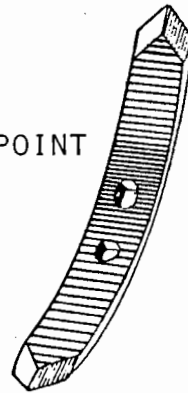

SWEEP

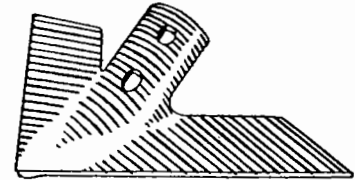

6" to 9"
47° Stem Angle

YOUR FIELD CULTIVATOR HAVING FIELD PROBLEMS

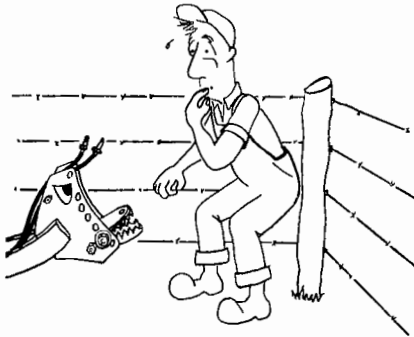

Don't let field problems back you into a corner. Turn to the back of this section and study the "SUGGESTED REMEDIES FOR POSSIBLE FIELD PROBLEMS" section.



DANGER:

THE WING-MOUNTED SHANKS AND POINTS CAN SERIOUSLY INJURY ANYONE THAT GETS TOO CLOSE. NEVER UNDER ANY CIRCUMSTANCES SHOULD ANYONE BE ALLOWED TO WALK OR WORK UNDER A WING THAT IS IN THE RAISED TRANSPORT POSITION.



SERVICING

GENERAL MAINTENANCE

All nuts should be checked and tightened during and after the first 1/2 day of operation, and periodically thereafter. Keep tires inflated to the recommended pressure, and check the wheel bolts until they are firmly seated. Hydraulic hoses should be checked for wear and pinched areas and replaced if necessary. Check shanks and mountings for looseness (tighten if necessary) and turn or replace points when worn.

NOTE: When turning or replacing points, be sure to turn or replace ALL of the points.



WARNING:

MAKE SURE ROAD LOCK ASSEMBLY IS PINNED OVER THE CYLINDER IN TRANSPORT POSITION BEFORE WORKING AROUND FIELD CULTIVATOR POINTS.

LUBRICATION

Regular lubrication of all grease fittings will help assure long life and satisfactory performance from the field cultivator. Use a multi-purpose type grease at all grease zerk locations after each 24 hours of operation. Rocker shaft bearing clamps will accept grease more efficiently if the whole unit is lowered to the ground with the weight of the unit removed from the wheels. Other points of lubrication are; wing hinges, and wheel hubs.

FOR YOUR SAFETY: WHEN LUBRICATING OR ADJUSTING YOUR FIELD CULTIVATOR, WATCH FOR OBTRUSIONS AND PROTRUSIONS. LOWER IMPLEMENT WING TO THE GROUND AND ENTER FRAMEWORK BE STEPPING OVER.

WHEEL BEARINGS

Grease wheel bearings every 24 hours of use. Check for excessive end play each time bearings are greased. Once a year, clean and repack wheel bearings with EP#2 Grease. Replace seals each time bearings are removed. Replace any worn or damaged parts. After repacking, place hub on spindle with seal and rear bearing already assembled. Use light oil on seal surface and use extreme care when pushing seal over the spindle. Install outer bearings, flat washer, and slotted nut. Tighten nut while turning hub until there is resistance to rotation. Then back off nut from 1 to 2 slots until hub turns freely without end play. Secure nut with clinched cotter pin.

HYDRAULIC SAFETY



HIGH PRESSURE FLUID FLOW CAN PENETRATE SKIN. IF INJURED BY ESCAPING HYDRAULIC FLUID, SEE A DOCTOR AT ONCE. SERIOUS INFECTION OR REACTION CAN DEVELOP IF PROPER TREATMENT IS NOT ADMINISTERED IMMEDIATELY.



ESCAPING FLUID FROM A SMALL HOLE CAN BE ALMOST INVISIBLE. USE CARDBOARD OR WOOD TO SEARCH FOR SUSPECTED LEAKS. DO NOT USE YOUR HANDS.

IF REPLACING HYDRAULIC HOSE, USE ONLY HOSE THAT MEETS OR EXCEEDS 2,500 P.S.I. WORKING PRESSURE.

BEFORE REMOVING ANY HYDRAULIC PARTS, ALWAYS RELIEVE HYDRAULIC PRESSURE BY TURNING OFF TRACTOR ENGINE AND MOVING TRACTOR CONTROL LEVER(S) BACK AND FORTH.

AIR IN THE HYDRAULIC SYSTEM WILL ALLOW THE CULTIVATOR OR WING TO DROP SUDDENLY. FILL THE HYDRAULIC SYSTEM BY EXTENDING AND RETRACTING THE CYLINDERS. HOLD THE CONTROL LEVER OPEN AND PAUSE AT THE END OF EACH STROKE OF THE CYCLES TO BLEED THE AIR FROM THE SYSTEM. CONTINUE THE CYCLES UNTIL THE CYLINDERS RESPOND WITH IMMEDIATE SOLID ACTUATION.

IMPORTANT: REPAIR OF HYDRAULIC CYLINDERS SHOULD BE MADE BY AN AUTHORIZED KRAUSE DEALER.

STORAGE

Select a level area, lower the wing and set the field cultivator down on blocks to prevent points from settling into the ground. Retract the gauge wheel hydraulic cylinders. Coat sweeps and hydraulic cylinder rods with rust preventative. Inspect for worn or damaged parts and replace as needed to avoid delays the next season. Check to be sure hydraulic hose couplers are stored on top of the tongue and not left laying on the ground.

REPAIR PARTS

Refer to the Assembly Section of this book when repairing or replacing parts, and follow the same procedure as used when assembling a new unit. Reverse this procedure for disassembly. The Parts Section of this book will show a breakdown of assemblies, location of parts, and part numbers.

KRAUSE parts were developed and tested for these units, therefore it is recommended that KRAUSE replacement parts be used.

NOTE: REPLACEMENT TIRES MUST HAVE A LOAD CAPACITY OF 3,000 LBS. AT 20 M.P.H.

SUGGESTED REMEDIES FOR POSSIBLE FIELD PROBLEMS

PROBLEM	POSSIBLE CAUSE	SUGGESTED REMEDY
PLUGGING	<i>Straw Is Dragging</i>	Work Deeper
	<i>"Bunched" Trash</i>	Work Shallow First Time
	<i>Field Is Too Wet</i>	Allow Field To Dry
	<i>Shanks Positioned Wrong</i>	Recheck Shank Spacing
NOT LEVEL FROM FRONT TO BACK WITH UNEVEN PENETRATION	<i>Clevis Height Not Adjusted When Depth Changed</i>	Use Wheels to Gage Depth And Adjust Clevis Height With Unit In Working Position
	<i>Some Weight Of Unit Not On Wheels During Leveling Adjustment</i>	
EXCESSIVE RIDGES	<i>Loose Point Or Sweep Bolts</i>	Tighten Plow Bolts Or Replace If Missing
	<i>Improper Shank Spacing Or Shanks Located Wrong</i>	Measure And Relocate. If Shank Is Shifting On Frame Make Sure Shank Is Straight Front To Back When Tightening Hex Nuts.
	<i>Bent Sweep</i>	Replace Sweep
	<i>Frame Not Level</i>	Level Frame At Operating Depth As Described In The Operating Instructions
	<i>Bent Shank</i>	Straighten Or Replace Shank
	<i>Wrong Stem Angle On Points</i>	Use Points With 47° Stem Angle
FIELD CULTIVATOR WILL NOT LOWER	<i>Road Lock Assembly Pinned</i>	Extend Depth Cylinder And Unpin Road Lock
	<i>Hose Couplers Not Locked In Tractor Sockets</i>	Check Hydraulic Hose Connector
	<i>Oil Not Flowing Through Hydraulic System</i>	Plugged Line Or Cylinder Port

PROBLEM

POSSIBLE CAUSE

SUGGESTED REMEDY

FIELD CULTIVATOR
DOES NOT FOLLOW
DIRECTLY BEHIND
THE TRACTOR

- Points Are Different Length — Replace Or Turn
- Bent Shanks — Replace Or Straighten
- Wing Out Of Adjustment — Re-adjust Wing Cylinder Lug. See Page 09
- Tire Size Or Air Pressure —
 - All Tires Should Be Within a $\pm 1/2$ " Diameter
 - All Tires Should Have Same Air Pressure
- Shank Locations Wrong —
 - Check Shank Spacing And Correct If Necessary
 - Check Shank Locations For Wrong Placement. Relocate Correctly. See Page A14-15
- Master Cylinder Stop Collars Not Set — Re-adjust Stop Collar
- Slave Cylinder Out Of Phase — Raise Unit Out Of Ground And Hold Control Lever Open Until All Cylinders Are Completely Extended

MAIN SECTION NOT
LEVEL FROM SIDE
TO SIDE

- Incorrect Tire Pressure — Check Tire Pressures 10:00 X 15 Tires Require 36 P.S.I.
- Bent Or Twisted Rocker Shaft Or Wheel Arm — Replace Or Straighten
- Incorrect Assembly Of Wheel Hubs — See Page A4 In Assembly Section

WING NOT LEVEL
FROM SIDE TO
SIDE

- Wing Too High Or Wing Too Low —
 - Check Field Adjustments On Page 09
 - Check Field Adjustments On Page 09
- Wing Lift Cylinder Not Fully Extended — Extend Cylinder To Maximum Length And Hold Open Briefly

(Continued)

PROBLEM	POSSIBLE CAUSE	SUGGESTED REMEDY
(Continued From 016)		
WING NOT LEVEL FROM SIDE TO SIDE	<i>High In Center - Due To Hard Soil Conditions</i>	Readjust Spring Tension On Spring Trunnion On Rod End Of Wing Lift Cylinder See Page 09
WING WILL NOT FOLD TO TRANSPORT POSITION	<i>A Plugged Restrictor In Wing Lift Cylinder</i>	Remove, Check & Clear Any Foreign Material That Might Plug Small Orifice in Restrictor At The Rod End Of Cylinders
	<i>Insufficient Hydraulic Pressure</i>	Check Tractor Hydraulic System
WING WILL NOT LOWER	<i>Wings Are Locked With Pins</i> <i>Hose Couplers Not Locked In Tractor Disconnect Socket</i>	Unpin Wing Check Hydraulic Hose Connector
WHEELS HAVE EXCESSIVE WOBBLE	<i>Loose Wheel Bolts</i> <i>Loose Spindle Nut</i>	Stop - Torque Wheel Bolts From 90 to 95 Ft. Lbs. Tighten Spindle Nut Turn Back One Notch And Pin
SETTLING OR CONTINUALLY GOING DEEPER WHILE WORKING	<i>Hydraulic System</i>	Set Cylinder Stop Collars On Master Cylinder Install New Cylinder Seal Kit In Faulty Cylinder. See P15 through P17 Check For Leaks In Hydraulic System Tractor Valve Is Leaking
WING WILL NOT FLEX DOWN	<i>Wing Lift Cylinder Is Not Fully Extended</i>	Extend Wing Lift Cylinder To The Maximum Length

PROBLEM	POSSIBLE CAUSE	SUGGESTED REMEDY
FIELD CULTIVATOR WILL NOT PENETRATE *(IMPORTANT) DO NOT REMOVE SHANKS	<i>Sweeps Have Wrong Angle</i>	Use 47° Stem Angle
	<i>Ground Is Too Hard</i>	Wait For Moisture
	<i>Dull Points</i>	Replace Or Turn Over
	<i>Excessive Field Speed</i>	Slow To 5 MPH Or Less
	<i>Incorrect Stroke Control Setting On Depth Cylinder</i>	Remove Hydraulic Stop Collars

*NOTE: Removing shanks to obtain additional depth will cause the remaining shanks, and frame members on which these shanks are mounted to be overloaded. This could cause bent shanks, broken bolts or clamps, or twisted frame members.

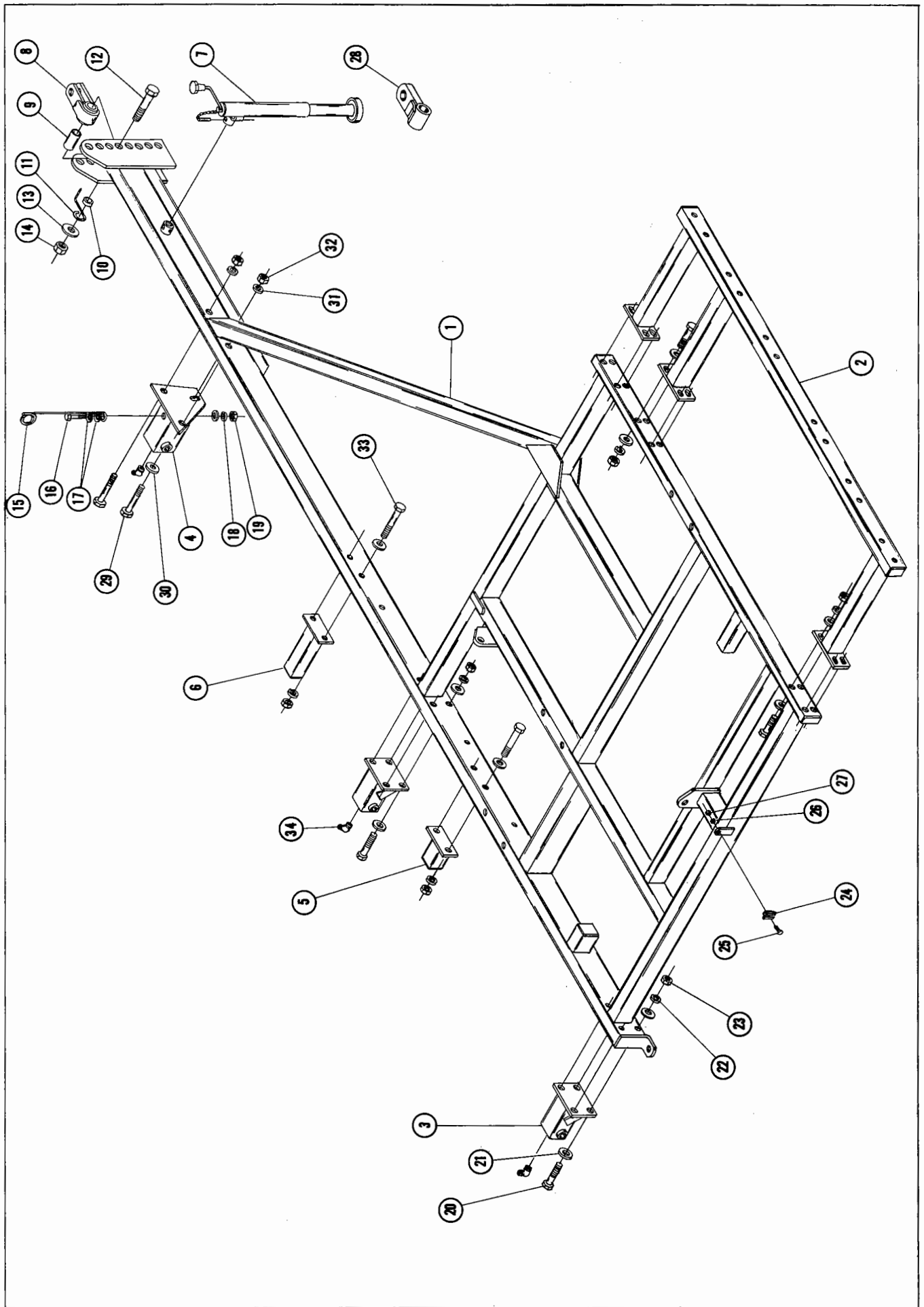

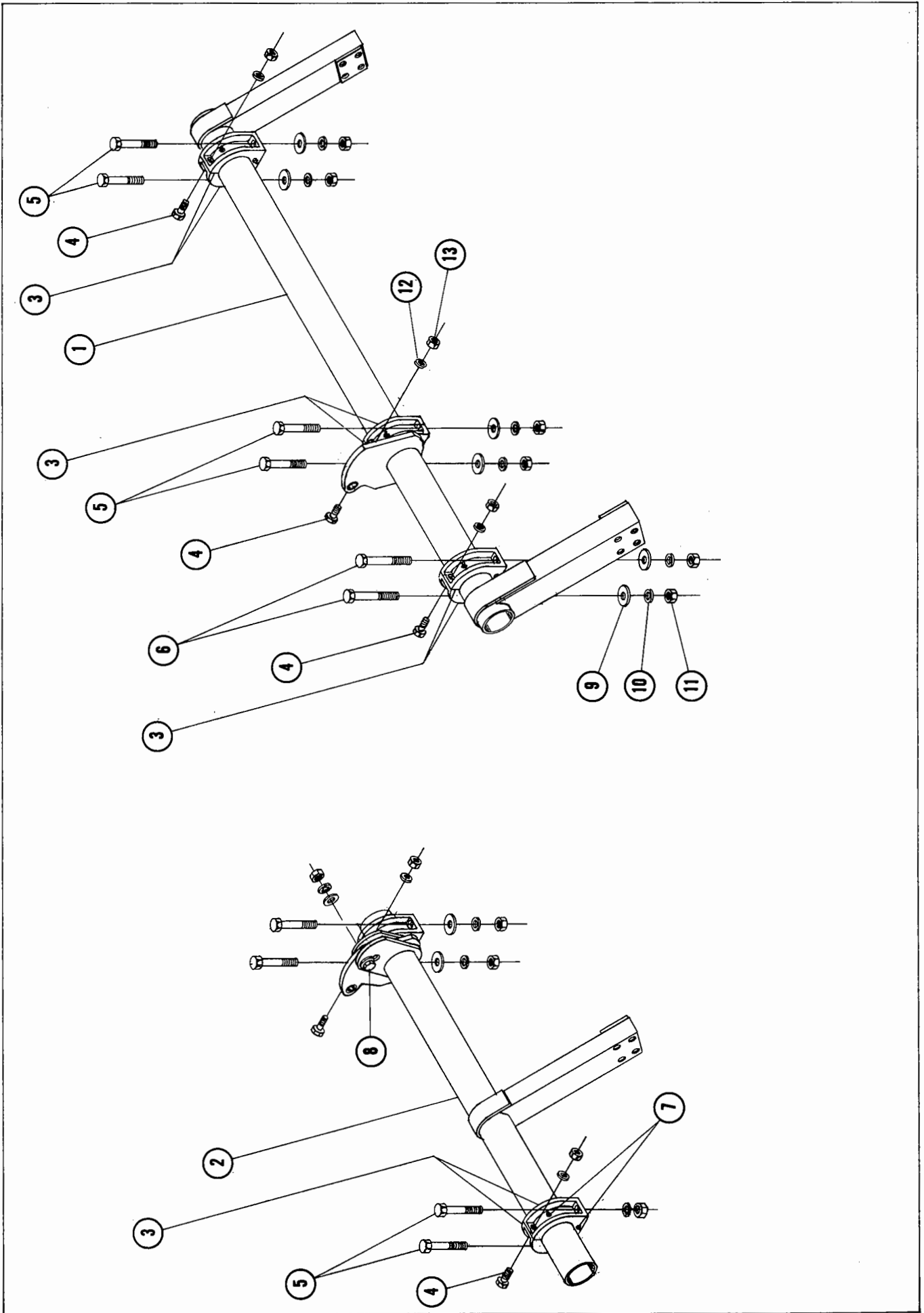

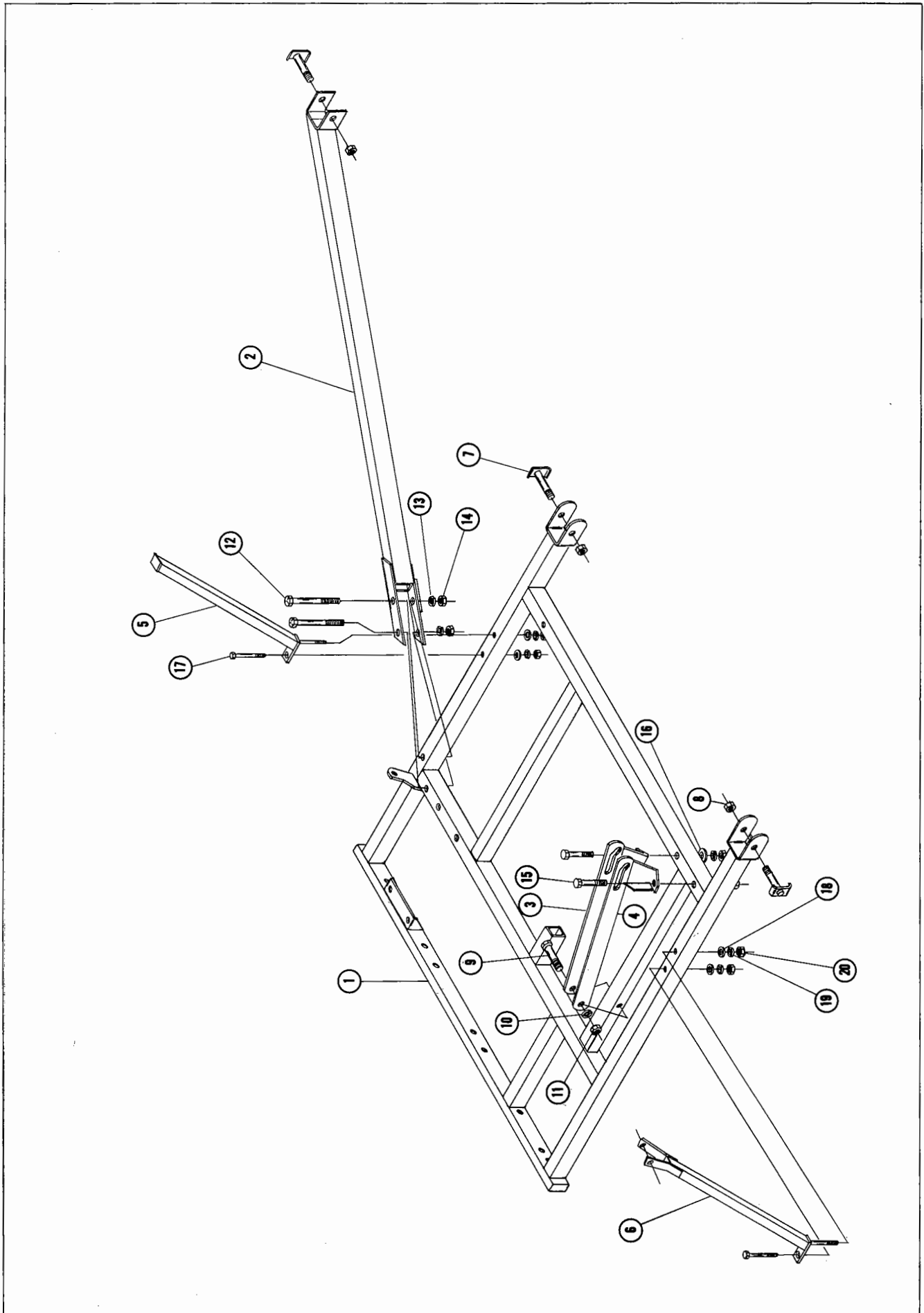

HUB ASSEMBLY

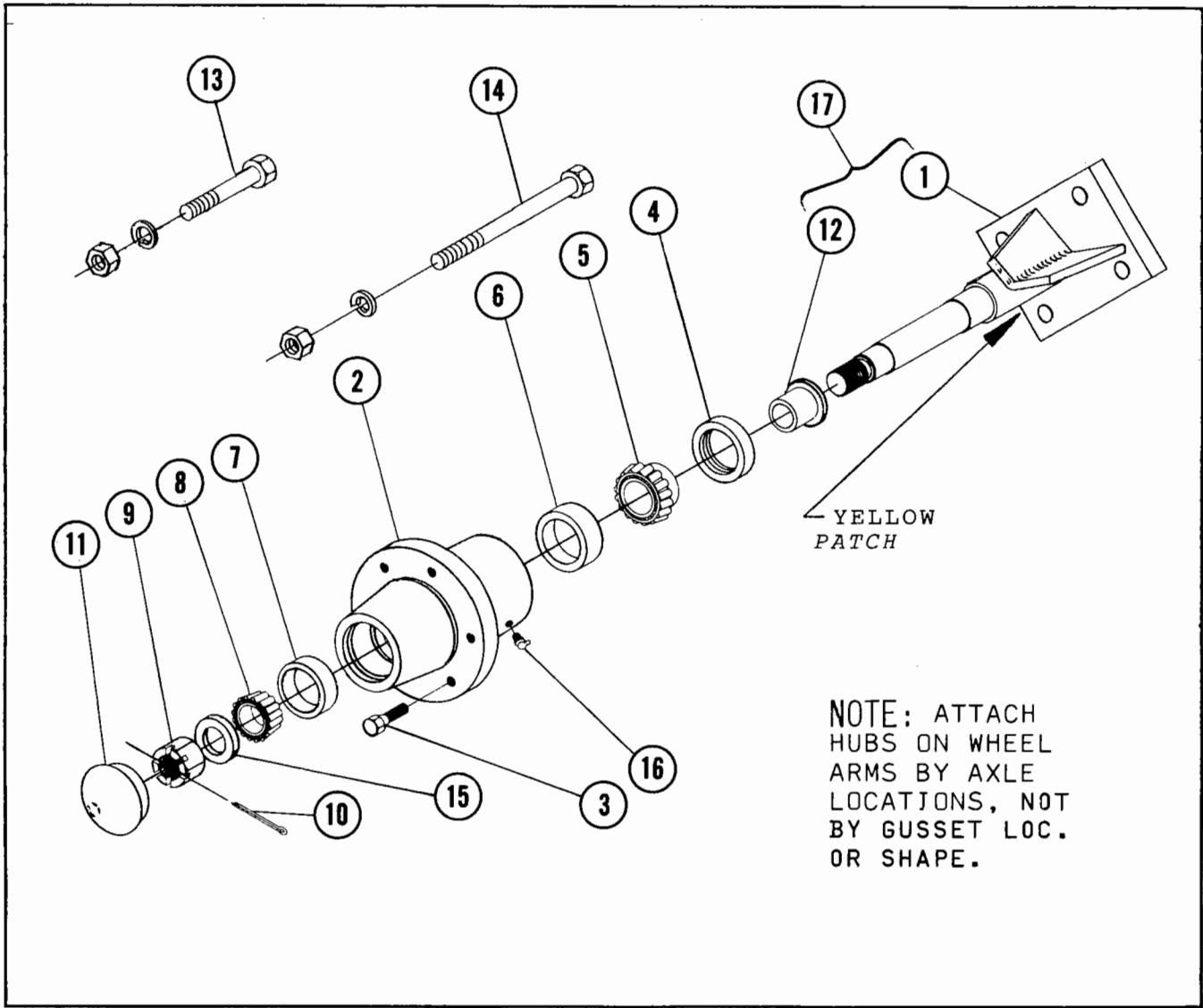

ITEM	PART NUMBER	PART DESCRIPTION	QUANTITY
	1918-17-0	Hub & Axle Assembly	Specify
1	1918-12-0	Stub Axle Weldment	1
2	1918-8-1	Hub Casting	1
3	62-295	Wheel Bolt	6
4	42-108	Seal	1
5	41-113	Cone	1
6	41-209	Cup	1
7	41-208	Cup	1
8	41-112	Cone	1
9	63-204	1NF Slotted Hex Nut	1
10	60-702	3/16" Dia. X 1-1/2" Cotter Key	1
11	52-302	Hub Cap	1
12	53-105	Wear Ring	1
*13	3/4NC X 5-1/2"	Cap Screw, Lock Washer & Hex Nut (OUTSIDE HUBS)	4 Per Hub
*14	3/4NC X 6-1/2"	Cap Screw, Lock Washer & Hex Nut (CENTER HUBS)	4 Per Hub
15	64-120	1" SAE Flat Washer	1
16	65-104	1/4NPT X 90° Zerk	1
17	1918-15-0	Repair Spindle & Sleeve Assembly	

* Not Part Of Assembly

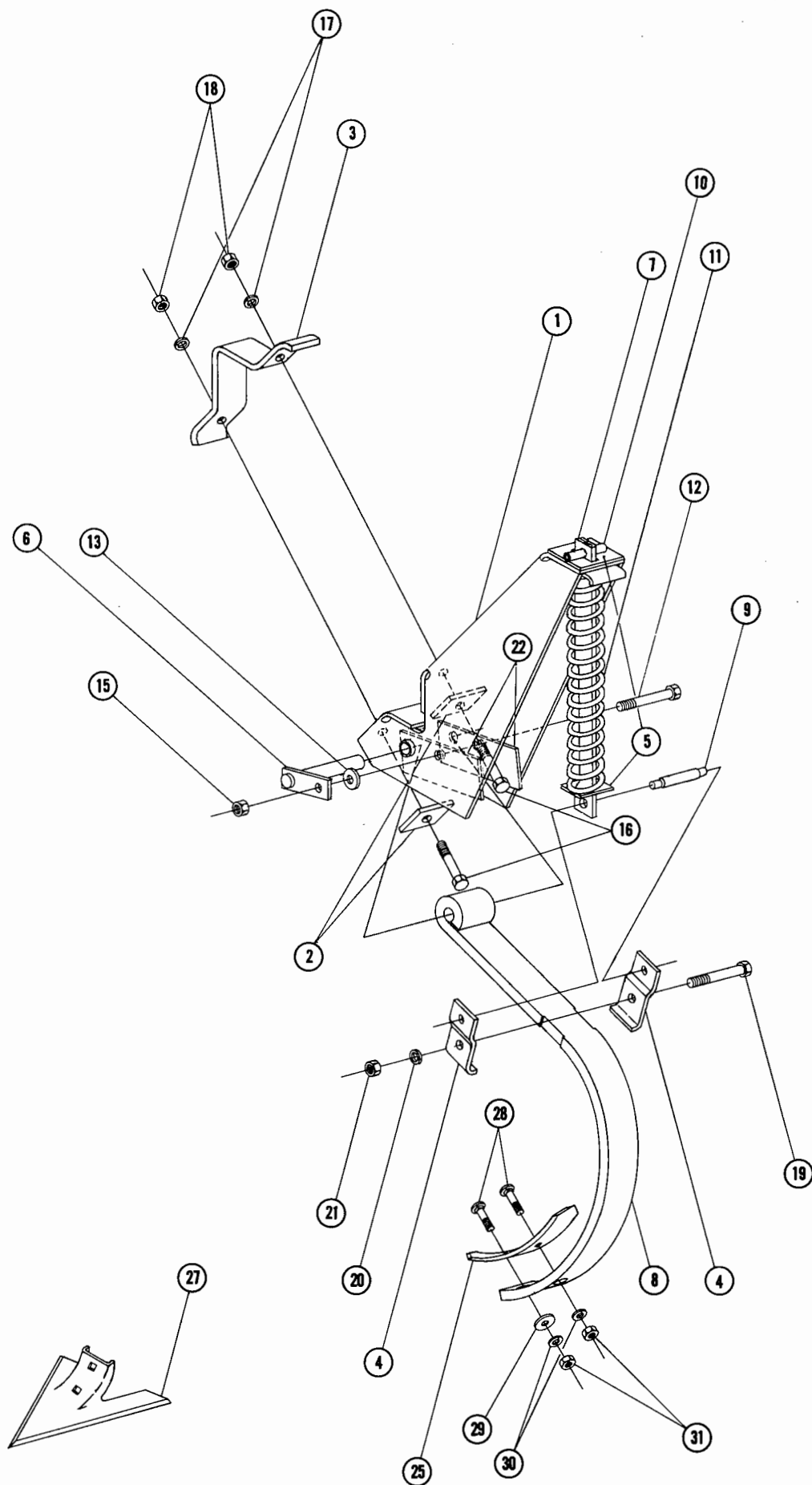

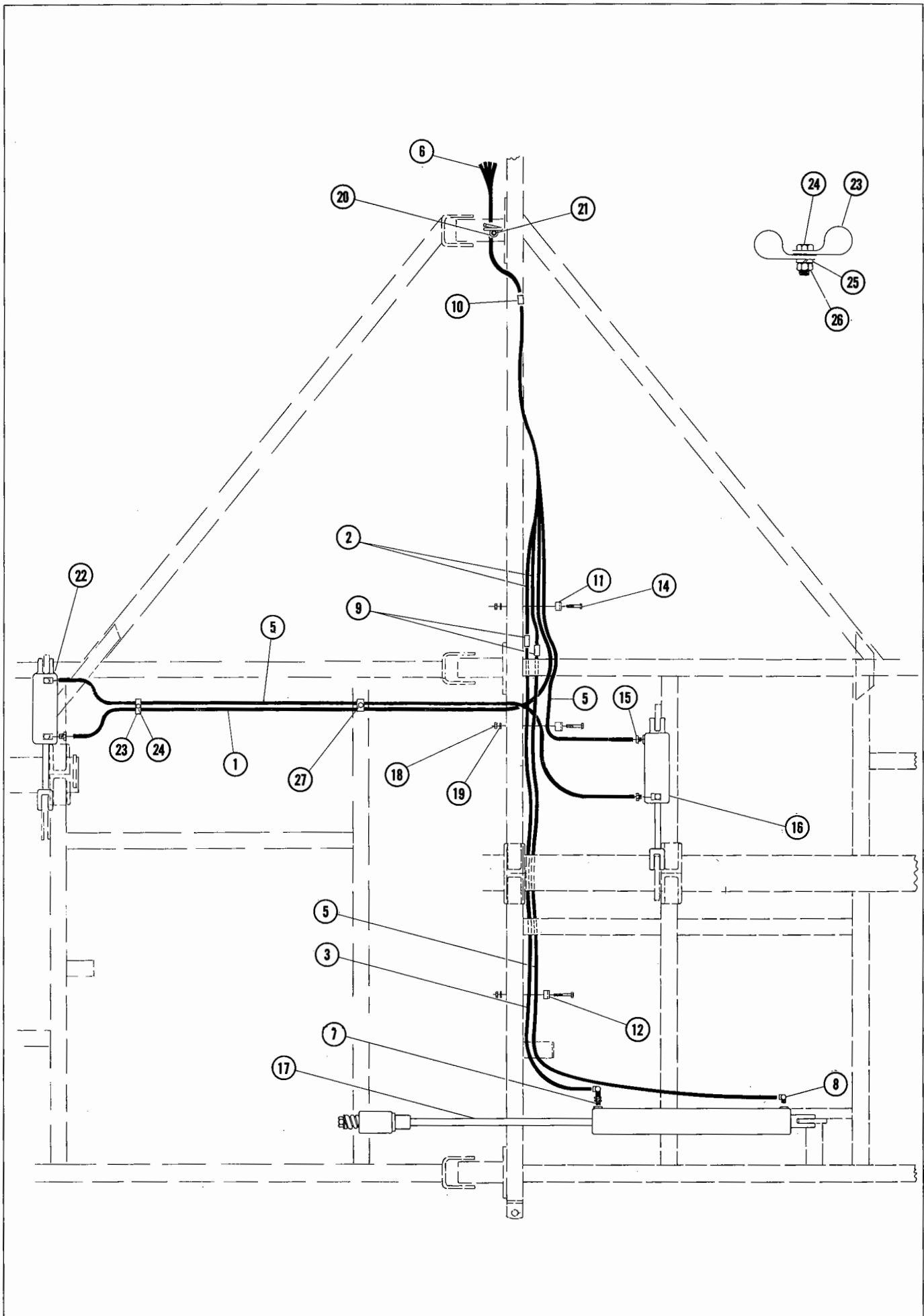

PRINCE HYDRAULIC CYLINDER

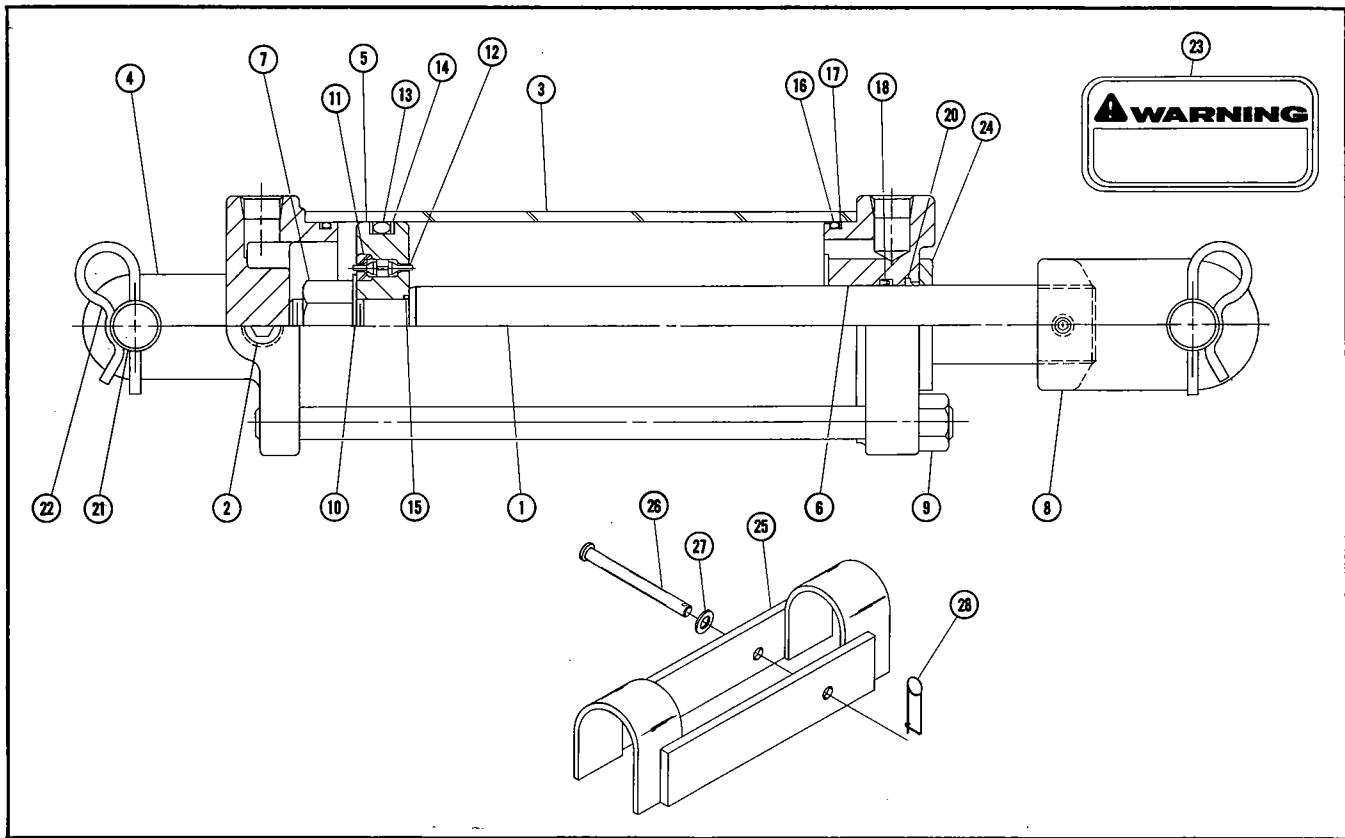

21-114 4" X 8" REPHASING HYDRAULIC CYLINDER (MASTER)
 Retracted - 20-1/4" Stroke - 8" Extended - 28-1/4" Rod - 1-1/2" 1/82

ITEM	PART NUMBER	PART DESCRIPTION	QUANTITY
1	21-336	Piston Rod	1
2	21-281	Pipe Plug	1
3	21-256	Tube	1
4	21-337	Butt	1
5	21-338	Piston	1
6	21-339	Gland	1
7	21-225	Lock Nut	1
8	21-340	Clevis Assembly	1
9	21-259	Tie Rod	4
10	21-341	Steel Washer	1
11	21-333	Seat	1
12	21-334	Poppet	1
*13	21-290	O-Ring	1
*14	21-291	Back-Up Washer	2
*15	21-228	O-Ring	1
*16	21-244	O-Ring	2
*17	21-247	Back-Up Washer	2
*18	21-350	U-Cup	1
*20	21-231	Wiper	1
21	21-260	Clevis Pin	2
22	21-219	Hair Pin Clip	4
23	74-113	Cylinder Warning Decal	1
	21-343	Seal Kit (* Items Included In Kit)	
	4122-38-0	Road Lock Assembly	2
25	4133-37-0	Road Lock Weldment	1
26	60-210	3/8" Dia. X 4" Clevis Pin	1
27	64-102	5/16" STD. Flat Washer	1
28	60-104	Safety Pin	1

PRINCE HYDRAULIC CYLINDER

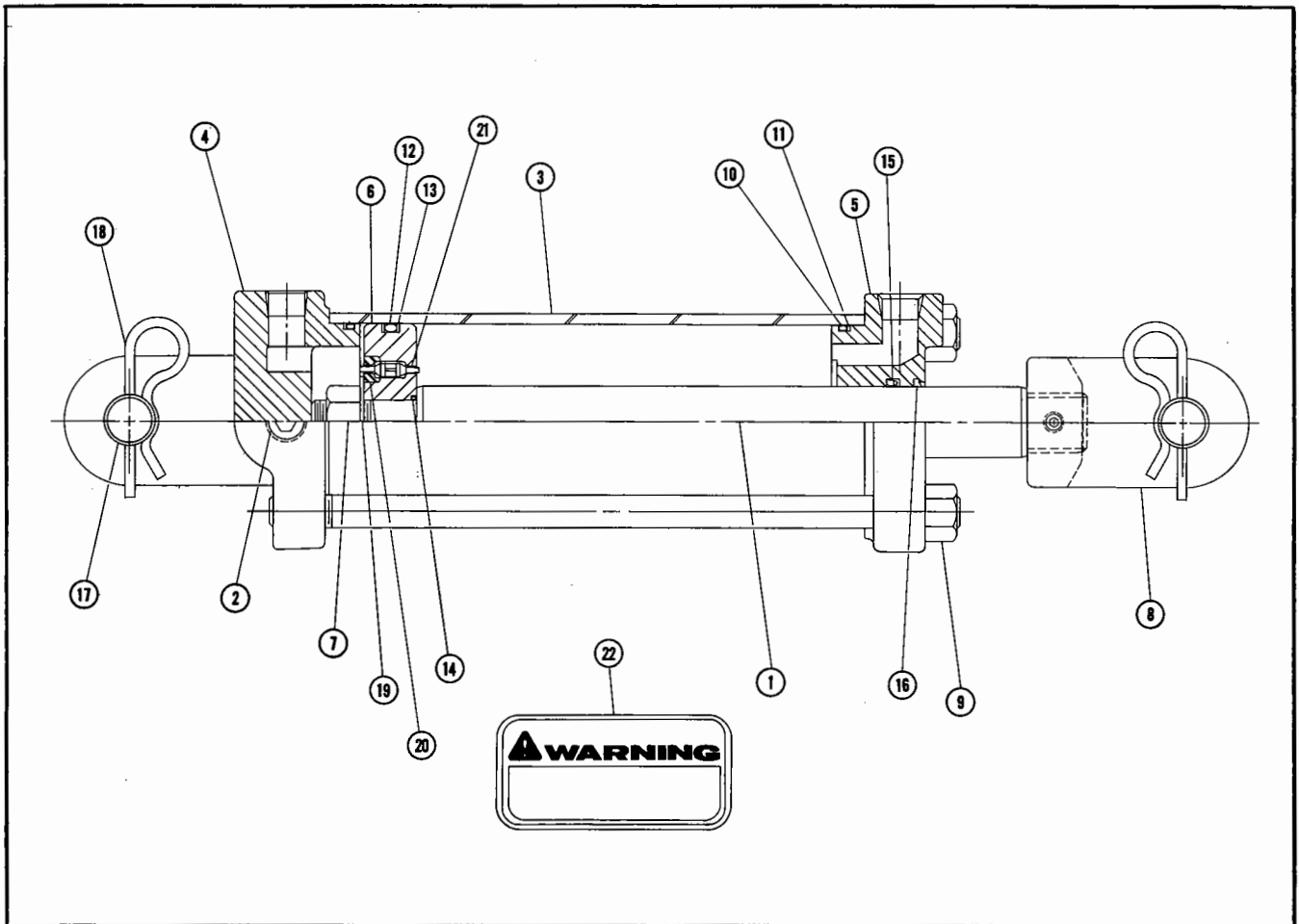

21-113 3-3/4" X 8" HYDRAULIC SLAVE CYLINDER 10/82
 Retracted - 20-1/4" Stroke - 8" Extended - 28-1/4" Rod - 1-3/8"

ITEM	PART NUMBER	PART DESCRIPTION	QUANTITY
1	21-347	Piston Rod	1
2	21-281	Pipe Plug	1
3	21-323	Tube	1
4	21-348	Butt	1
5	21-325	Gland	1
6	21-326	Piston	1
7	21-209	Lock Nut	1
8	21-327	Clevis Assembly	1
9	21-259	Tie Rod	4
*10	21-328	O-Ring	2
*11	21-329	Back-Up Washer	2
*12	21-330	O-Ring	1
*13	21-331	Back-Up Washer	2
*14	21-215	O-Ring	1
*15	21-351	U-Cup	1
*16	21-218	Wiper	1
17	21-260	Clevis Pin	2
18	21-219	Hair Pin Clip	4
19	21-332	Washer	1
20	21-333	Seat	1
21	21-334	Poppet	1
22	74-113	Cylinder Warning Decal	1
	21-335	Seal Kit (* Items Included In Kit)	

PRINCE HYDRAULIC CYLINDER

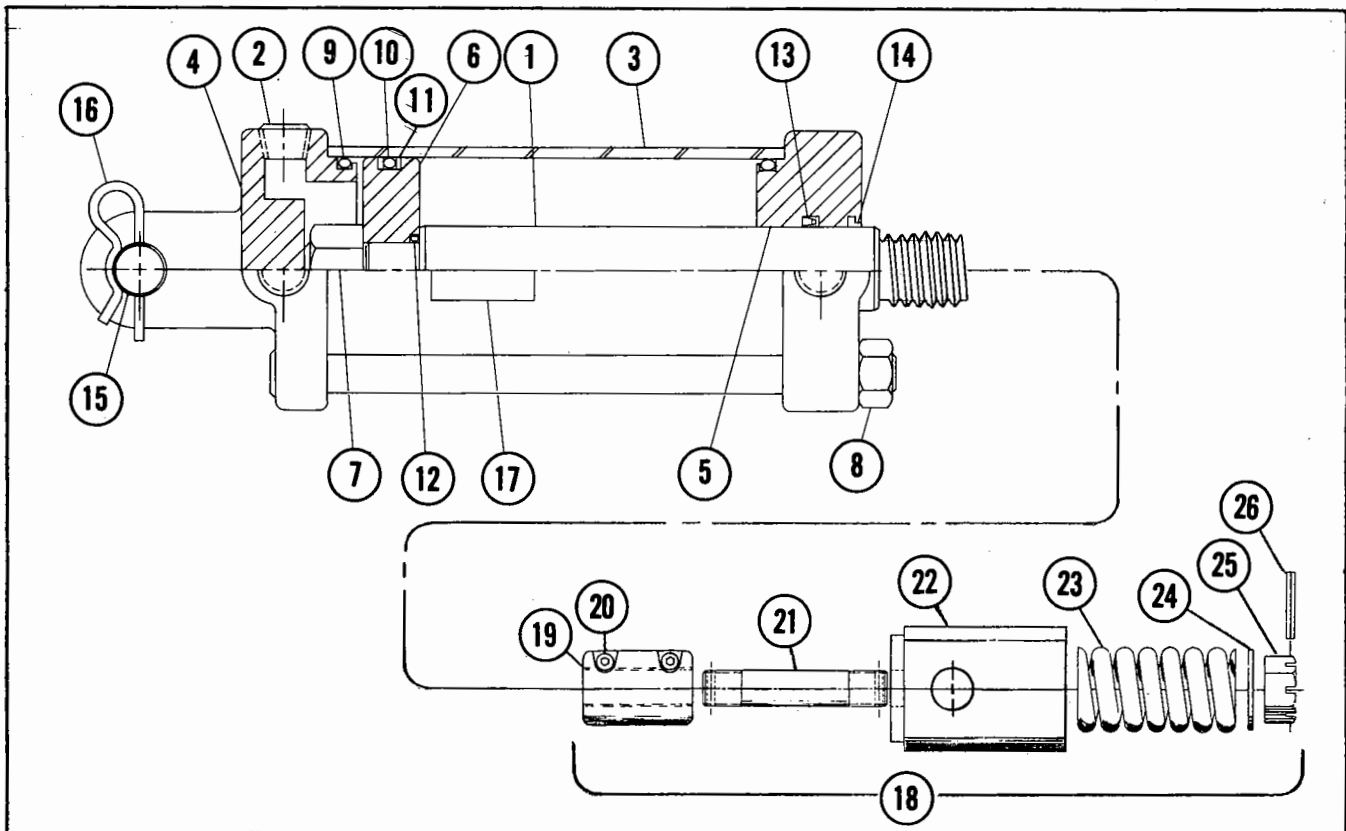

3514-90-0A 4" X 32" WING LIFT HYDRAULIC CYLINDER 11/82
 Retracted - 42-3/4" Stroke - 32" Extended - 76-3/4" Rod - 1-1/2"

ITEM	PART NUMBER	PART DESCRIPTION	QUANTITY
▲	21-107	4" X 32" Hydraulic Cylinder	1
1	21-265	Piston Rod	1
2	21-281	Pipe Plug (1/2" Socket Head)	1
3	21-266	Tube	1
4	21-283	Butt	1
5	21-223	Gland	1
6	21-224	Piston	1
7	21-225	Lock Nut	1
8	21-268	Tie Rod	4
*9	21-289	O-Ring	2
*10	21-290	O-Ring	1
*11	21-291	Back-Up Washer	2
*12	21-228	O-Ring	1
*13	21-350	U-Cup	1
*14	21-231	Wiper	1
15	21-296	Clevis Pin	1
16	21-219	Hair Pin Clip	2
17	74-113	Cylinder WARNING Decal	1
18	3514-92-0A	Spring Trunnion Assembly	1
19	2426-92-2B	Coupler	1
20	20-433	3/8NC X 1-3/4" Socket Head Cap Screw & Nut	2
21	3514-92-1	Spring Rod	1
22	2426-93-0	Trunnion Weldment	1
23	76-110	Spring	1
24	64-127	1-1/4" SAE Flat Washer	1
25	63-205	1-1/4NF Slotted Hex Nut	1
26	60-606	1/4" DIA. X 2" Roll Pin	1
	21-232	Seal Kit (* Items Included In Kit)	

▲ 21-107 Cylinder Clevis Assembly Replaced With Items 18 thru 26

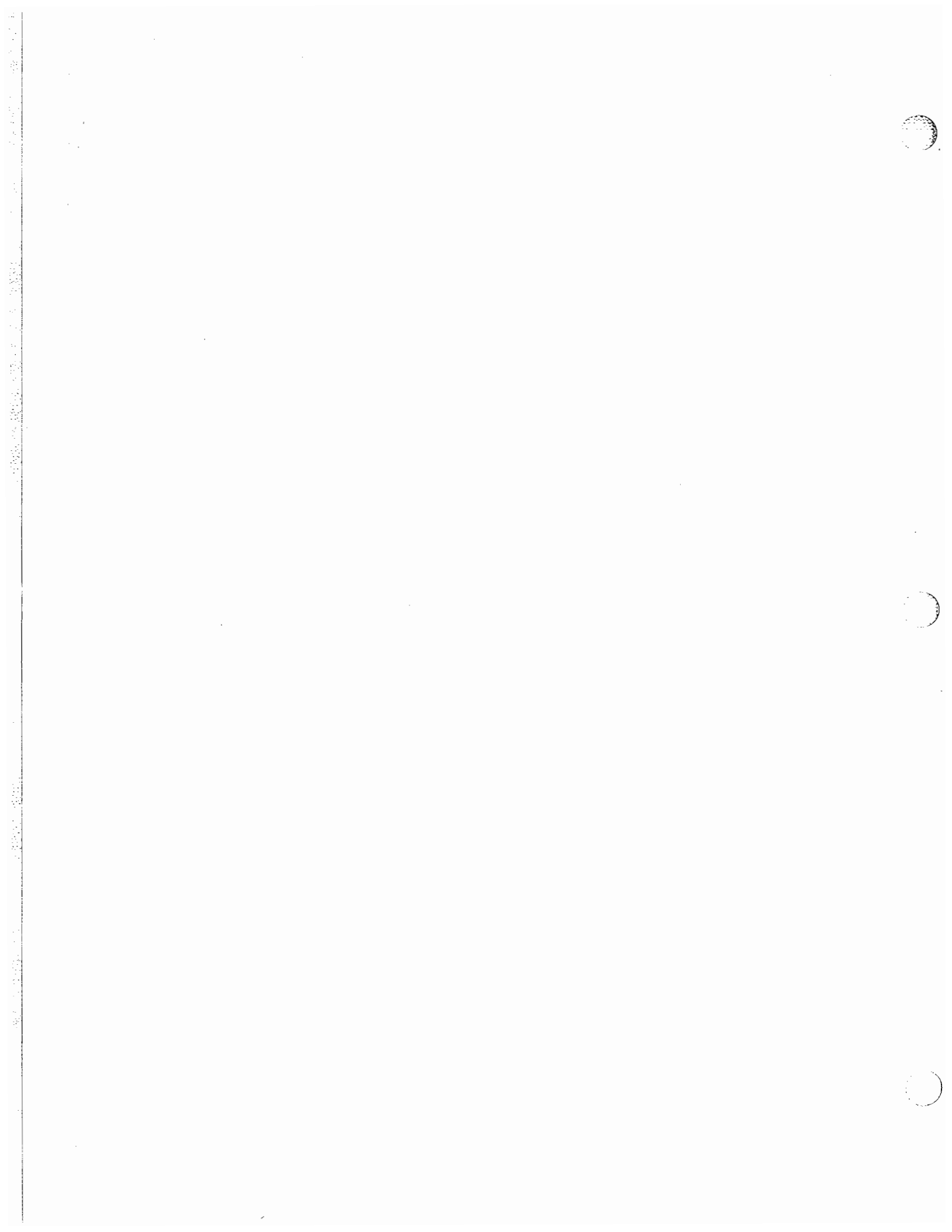

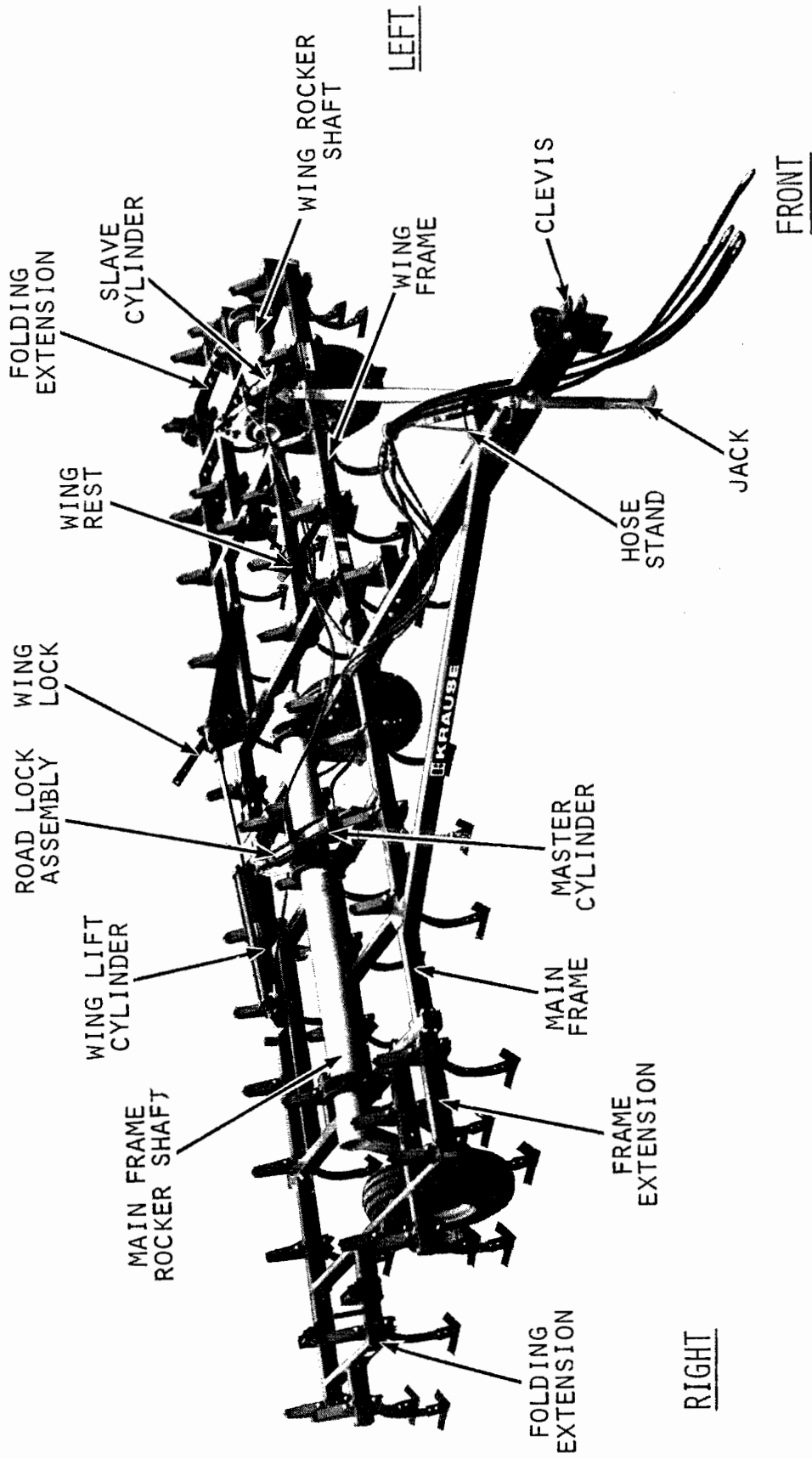

ASSEMBLY

STUDY THE NAMES AND LOCATIONS OF THE PARTS AND FAMILIARIZE YOURSELF WITH THE FIELD CULTIVATOR BEFORE STARTING THE ASSEMBLY. READING THE STEP BY STEP INSTRUCTIONS THAT FOLLOW WILL BE HELPFUL.

SAFETY



READ ALL THE SAFETY NOTATIONS IN THE ASSEMBLY INSTRUCTIONS FOR YOUR OWN PROTECTION. ACCIDENTS CAN BE PREVENTED BY RECOGNIZING THE CAUSE OF AN ACCIDENT BEFORE IT CAN HAPPEN.

ASSEMBLY

Select an area for the assembly that will be large enough to accommodate the completed field cultivator. The surface of the work area should be as level as possible. Use the proper hand tools to insure proper bolt tightness. Refer to the page titled "Proper Bolt Use" for the recommended torque values of different size bolts.

PART LOCATIONS

FRONT - The front of the frame can be determined by the location of the name plate that has been attached to the right front frame member.

RIGHT and **LEFT** sides can be established by standing behind the frame and looking toward the front, or the direction of travel.

TOP - To be sure the frame is right side up, position the frame with the wing lift hydraulic cylinder lug on top.

ASSEMBLY STEPS

Shown here is one method of assembly that can be accomplished with a small crew of assemblers. Each step of assembly is accompanied with a picture or illustration with part names and bolt sizes listed.



WARNING: ALWAYS ATTACH CHAINS SECURELY. IF A CHAIN WOULD BREAK, THE RECOIL ACTION COULD CAUSE THE LOOSE END TO WHIP IN ANY DIRECTION AND INJURE ANY PERSON NEARBY.

PROOF LOAD RATING OF CHAIN MUST EQUAL OR EXCEED FIVE TIMES THE WEIGHT BEING LIFTED.

THE HEAVIEST COMPONENT TO BE LIFTED IN PLACE IS THE CENTER FRAME WHICH WEIGHS 750 LBS.

MODEL NUMBER

Know the model number of the field cultivator being assembled. Use the model number whenever referring to the assembly, parts listing pages or placement drawings. The number is stamped on the NAME PLATE which is located on the front frame member.



STEP 1. FRAME

- (1) Position frame on suitable stands approximately 30" high with wing lift hydraulic cylinder lug on top. Stands must be able to support 2,000 lbs.

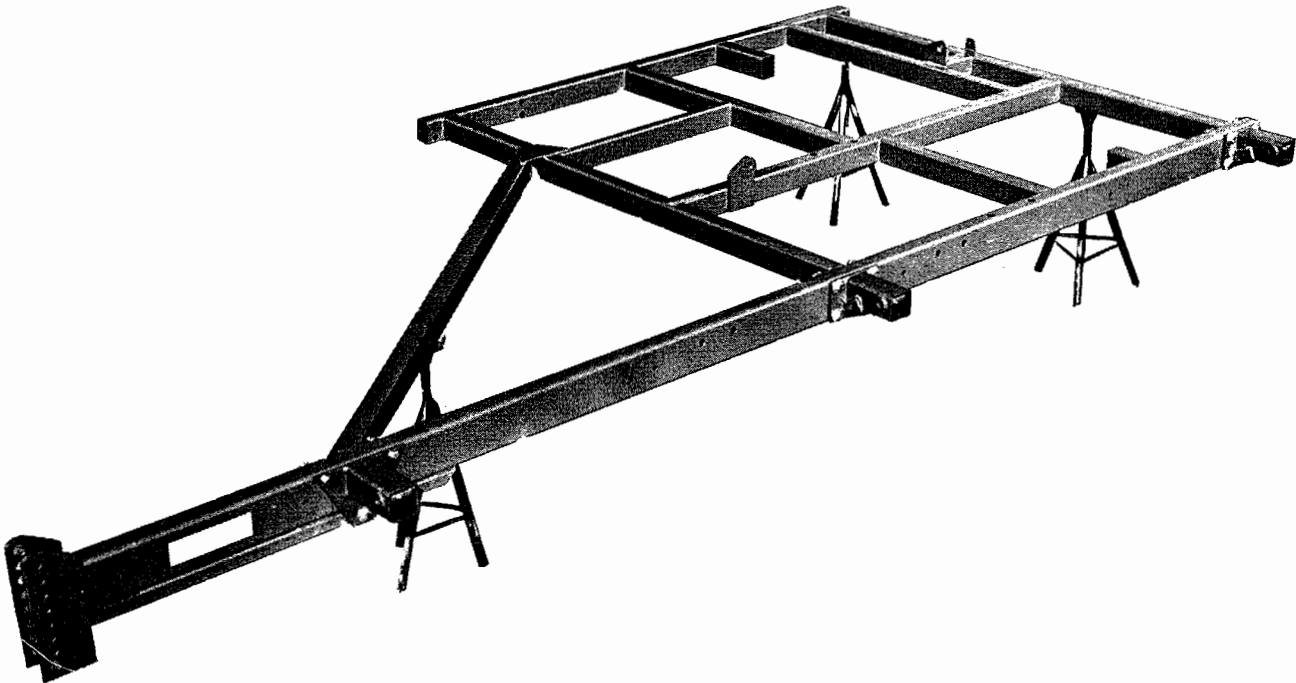

- (2) Bolt center and rear hinge brackets to main frame with 3/4NC X 5" Bolts - use flat washers on both sides of the tongue box. DO NOT TIGHTEN UNTIL WING FRAME IS MOUNTED.
- (3) Bolt front hinge bracket to tongue with 5/8NC X 5" Bolts - use a flat washer on the lower Bolt only. DO NOT TIGHTEN UNTIL WING FRAME IS MOUNTED.
- (4) Assemble a 45° Zerk in each of the hinge brackets.

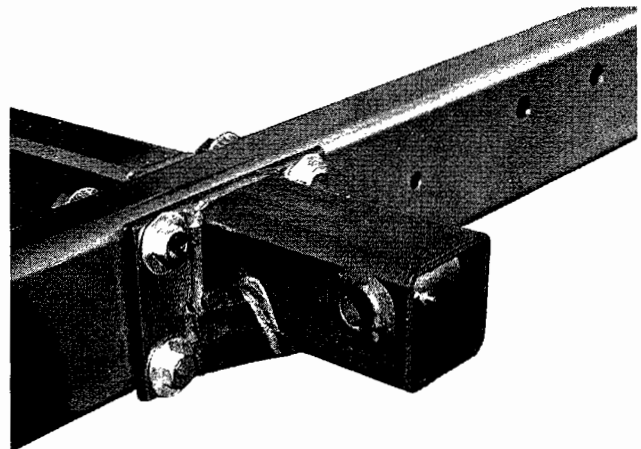

STEP 2. ROCKER SHAFT

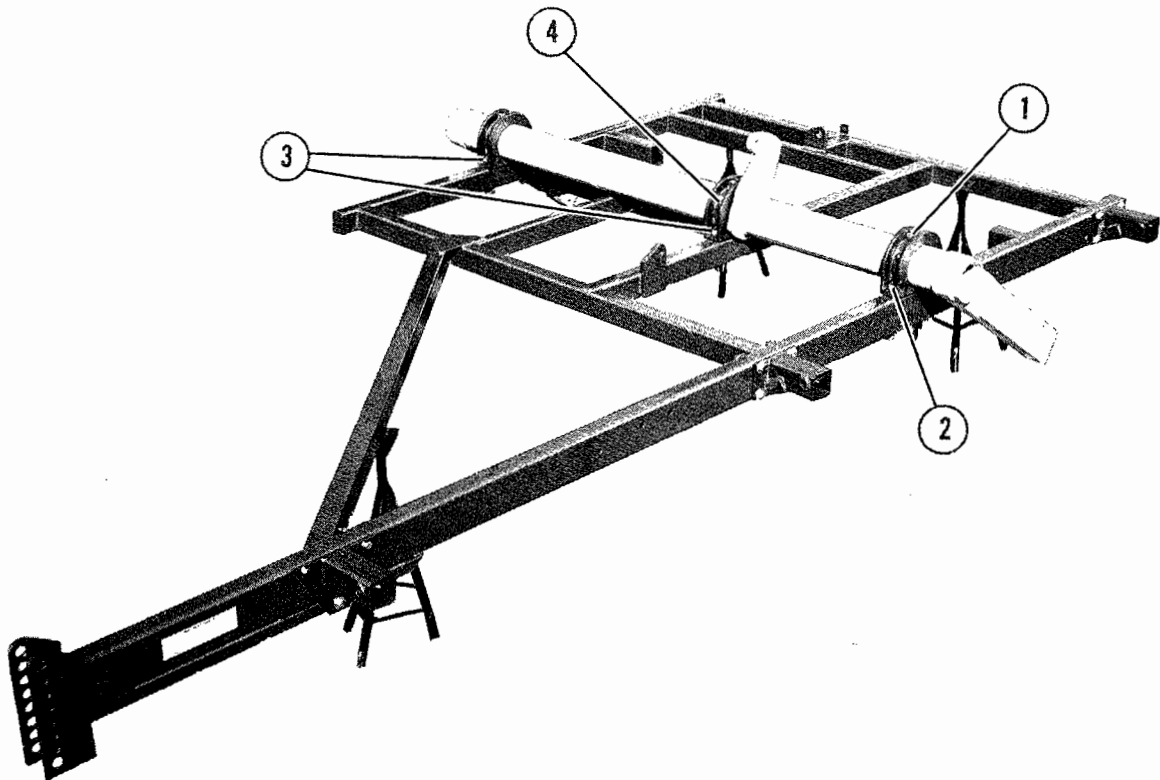

- (1) Clean paint and dirt from grease channels of cast HALF CLAMPS and assemble around the MAIN ROCKER SHAFT using 3/4NC X 2-1/2" GRADE 5 Bolt, Lock Washer and Hex Nut ①.
- (2) Lower MAIN ROCKER SHAFT over frame as shown.
 - ② 1NC X 8-1/2" Bolt, Hex Nut, Lock Washer and Flat Washer on CENTER FRAME BOX only.
 - ③ 1NC X 6-1/2" Bolt, Hex Nut, Lock Washer and Flat Washer on other members.
 - ④ TWO #1610 1/8NPT Zerks in each half clamp. (NOTE: Do not place zerk on side of rocker clamp directly beside the cylinder lug.)

STEP 3. WHEEL HUBS - MAIN SECTION

- (1) Mount WHEEL HUBS to wheel arm with YELLOW PATCH located as shown in photo at right. Center wheel hubs use 3/4NC X 6-1/2" Bolt, Lock Washer & Hex Nut - right wheel hub use 3/4NC X 5-1/2" Bolt, Lock Washer & Hex Nut.

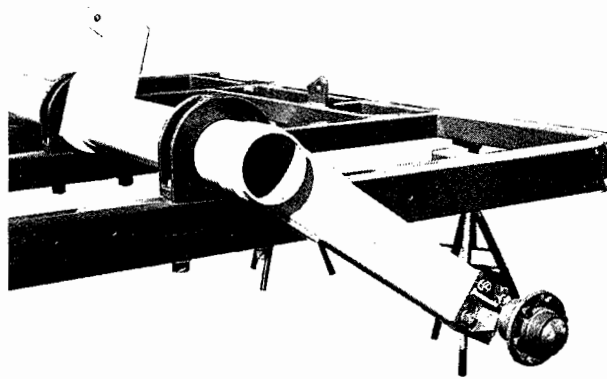

- (2) Remove the WHEEL BOLTS from the hubs and attach the WHEEL & TIRE ASSEMBLIES to the hubs.

TORQUE ALL WHEEL BOLTS FROM 90 TO 95 FT. LBS. INFLATE TIRES TO 36 P.S.I.

CENTER MAIN SECTION
WHEEL ARM

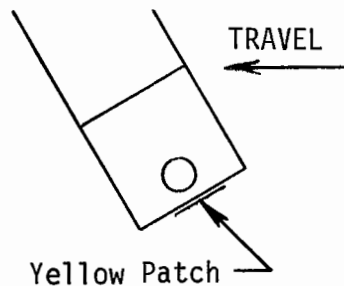

Figure 1

RIGHT MAIN SECTION
WHEEL ARM

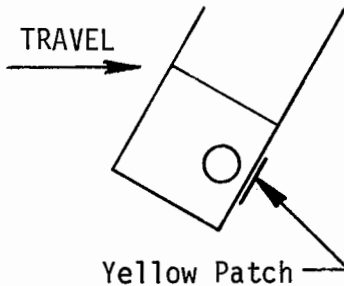
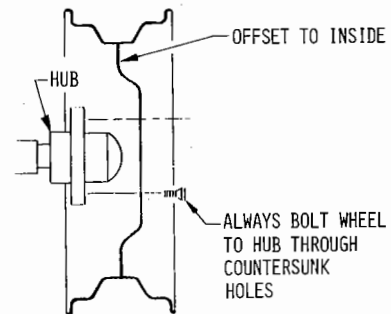
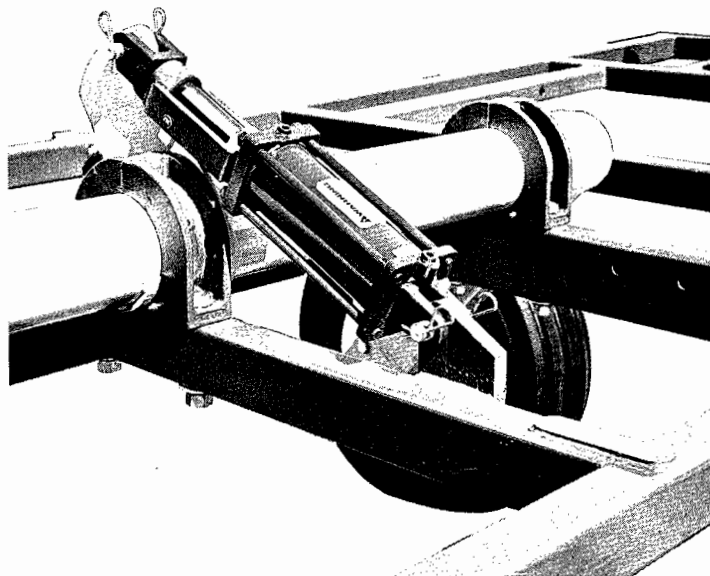

Figure 2



STEP 4. HYDRAULIC CYLINDER - MAIN SECTION AND ROAD LOCK

- (1) Remove port plugs from the 4" Diameter X 8" cylinder and fully extend.
- (2) Place ROAD LOCK ASSEMBLY part number 4122-38-0 over the cylinder rod and secure with pin and flat washer.
- (3) Lift the frame and pin the cylinder between the rocker shaft cylinder lug and the frame cylinder lug.



STEP 5. TONGUE JACK AND HOSE CARRIER

- (1) The TONGUE JACK is mounted over a tube welded on the right side of the tongue.
- (2) The HOSE CARRIER is mounted on the top side of the front hinge bracket. Use 1/2NC X 5-1/2" Bolt, THREE Flat Washers (two between bolt head and hose carrier), Lock Washer and Hex Nut.

STEP 6. FREE STANDING CENTER SECTION AND FRAME EXTENSION

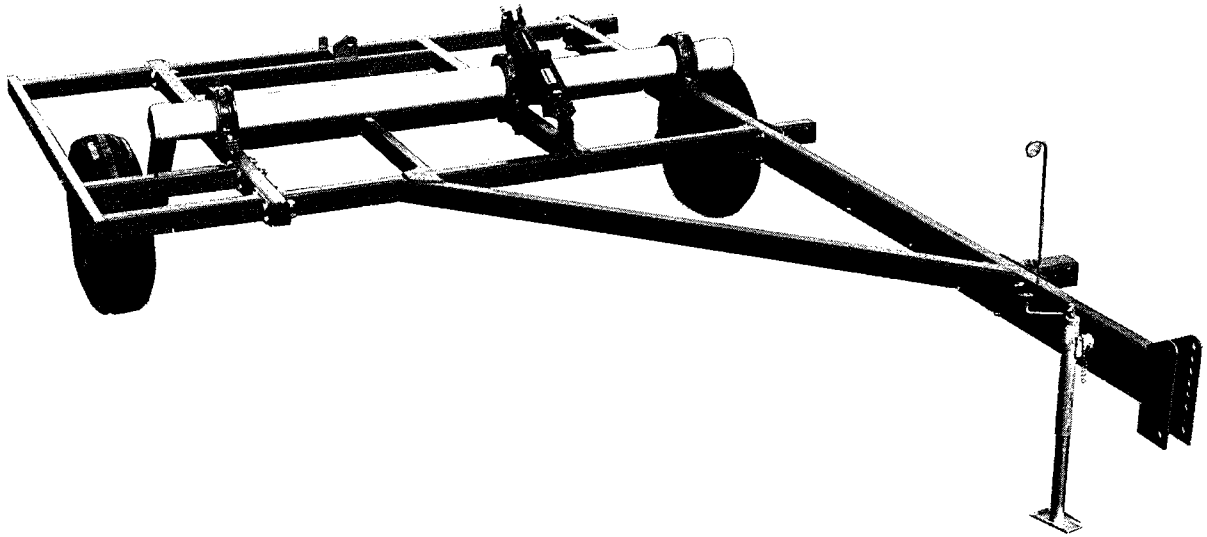

- (1) Tighten all **ROCKER SHAFT AND WHEEL** bolts. The center section will now stand by itself and the stands can be removed.
- (2) Place frame extension on outside of main section with the two bars toward the front. Use 3/4NC X 5" Bolts, hex nuts, lock washers. Use Flat Washers on both sides of bolt. On the front two beams place the bolts through from the outside, and on the rear beam place the bolts through from the inside.

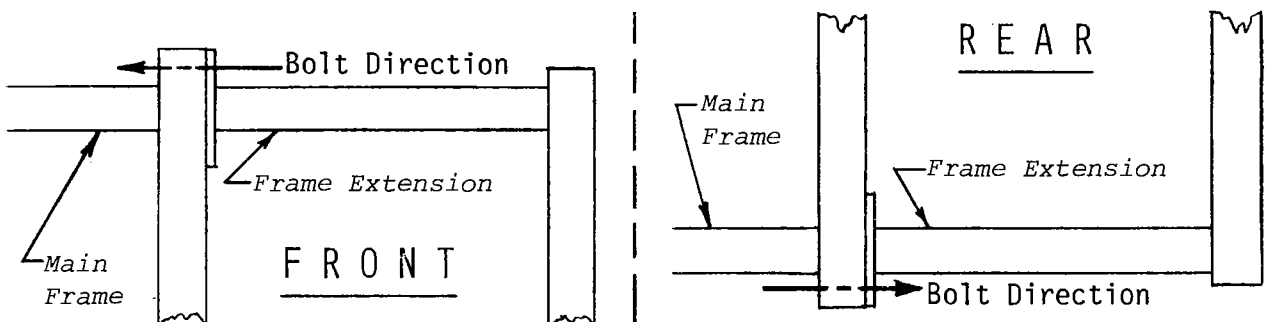

STEP 7. SHANK EXTENSIONS - MAIN SECTION

- (1) Place SHORT SHANK EXTENSION on outside of tongue member between the rocker shaft and the front frame member. Use 3/4NC X 4-1/2" Bolts with Flat Washers on the back side.
- (2) Place LONG SHANK EXTENSION on outside of tongue member in front of the front frame member. Use 3/4NC X 4-1/2" Bolts with Flat Washers on the back side.

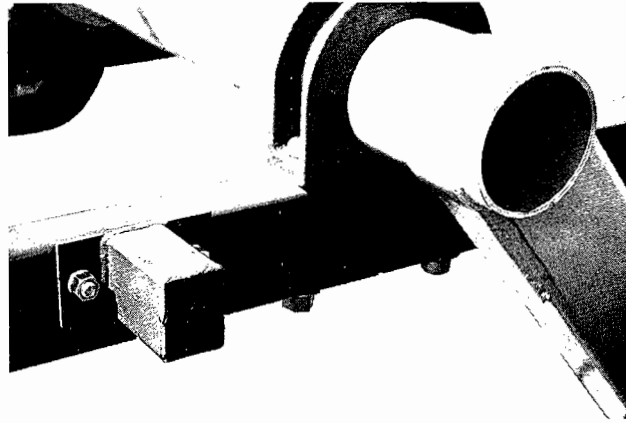

STEP 8. WING FRAME TO MAIN SECTION

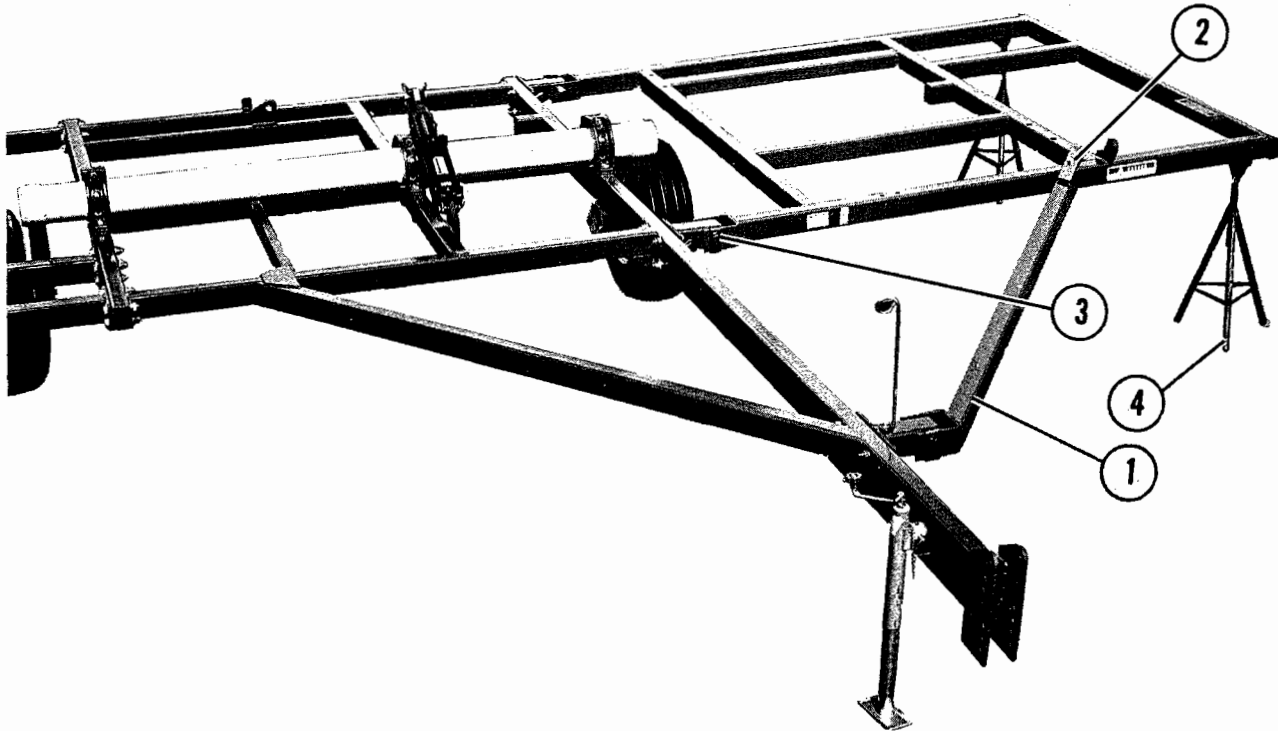

- (1) Attach WING BRACE to wing frame ① with 3/4NC X 7" GRADE 5 Bolts ② . DO NOT TIGHTEN NUTS.
- (2) Position WING FRAME beside the main frame with rear frame members in a straight line. Lift into place and secure with 3514-42-0 Wing Hinge Bolts and 1NC Self Locking Nuts ③ . Place a stand under the outer end of the wing ④ .
- (3) TIGHTEN wing hinge bracket bolts to the main section frame, and wing brace bolts to the wing at this time.

STEP 9. HITCH ASSEMBLY

- (1) Assemble the HITCH CLEVIS with the 3940-0-1 SPACER inside with 1-1/4NC X 6-1/2" Machine Bolt. Before assembling 1-1/4NC Self Locking Nut, slide on a 1901-0-21 BUSHING, a 76-119 CLEVIS SPRING, and a 1-1/4" STD. Flat Washer.

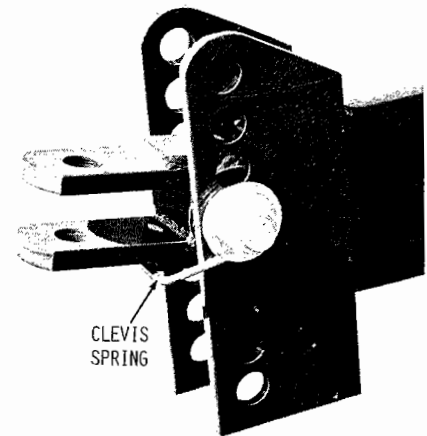

STEP 10. WING ROCKER SHAFT

- (1) Repeat Step 2 with cast HALF CLAMPS.
- (2) Lower WING ROCKER SHAFT over frame as shown.

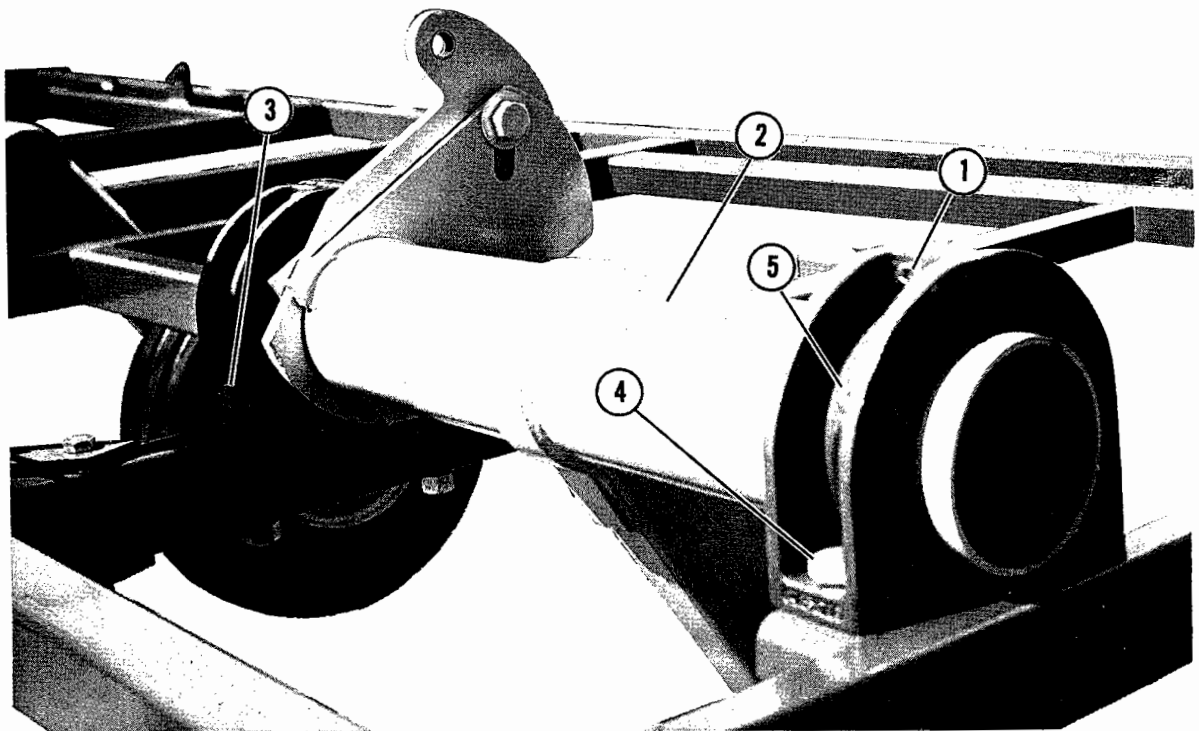

- (3) With 1NC X 6-1/2" Bolt, Hex Nut and Lock Washer, bolt inside castings to wing frame, using flat washer on bottom side of frame.
- (4) With 1NC X 3" Bolt, Hex Nut and Lock Washer, bolt outside casting to frame.
- (5) Add TWO Zerks to each rocker clamp casting. (NOTE: Do not place zerk on side of rocker clamp directly beside the lug.)

STEP 11. WING WHEEL AND HYDRAULIC CYLINDER

- (1) Remove port plugs from the 3-3/4" Diameter X 8" cylinder and fully extend.

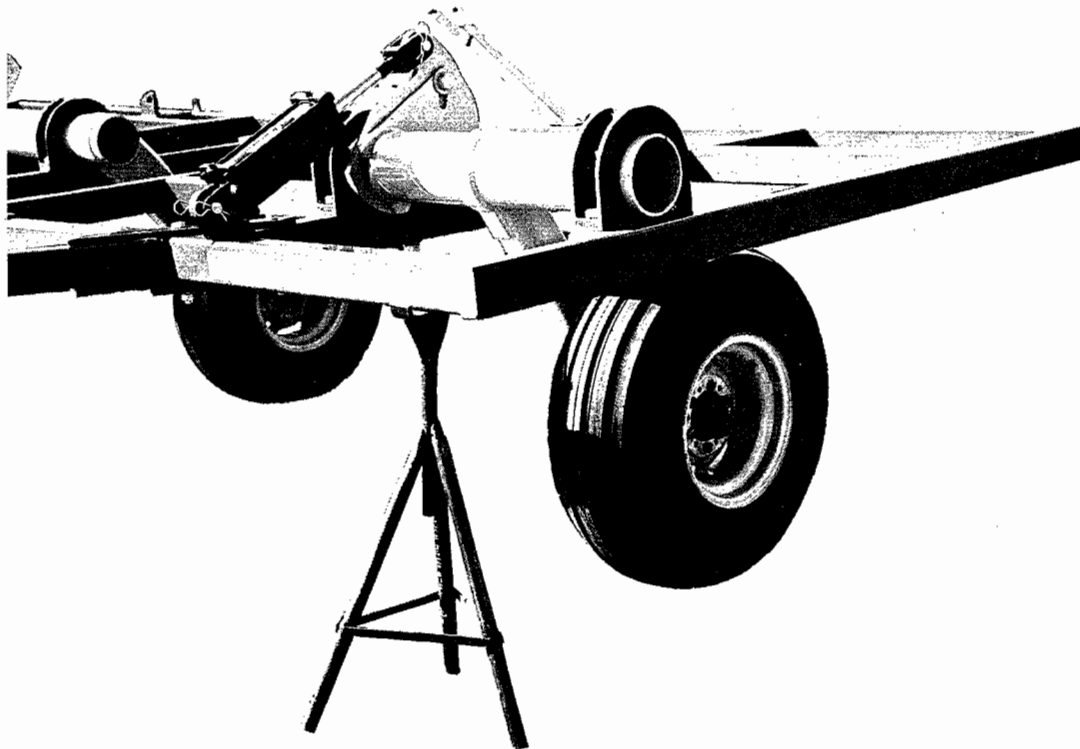

- (2) Attach cylinder between wing rocker and frame.
- (3) Repeat Step 3 "WHEEL HUBS". Use 3/4NC X 5" Bolts, Lock Washers, Flat Washers and Hex Nuts. (Flat Washers should be under bolt head)
- (4) Locate YELLOW PATCH at end of wheel arm - See Figure 1 on A4.

STEP 12. WING LOCK AND WING REST

- (1) Attach WING LOCK (Part Number 3942-27-0) to rear frame member with 5/8NC X 5-1/2" Bolt, Lock and Flat Washer, and Hex Nut.
- (2) Attach WING STOP (Part Number 3942-29-0) to front frame member with 5/8NC X 5-1/2" Bolt, Lock and Flat Washer, and Hex Nut.

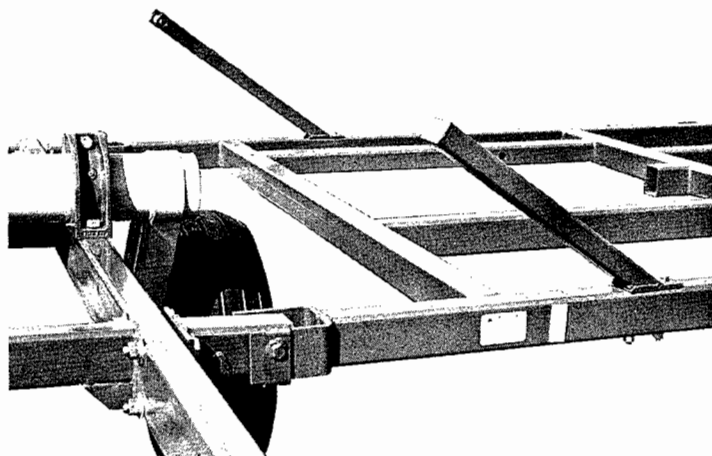

STEP 13. WING LIFT BRACKETS

(1) Mount Wing Lift Brackets to the rear of the Wing Frame with 1NC X 6-1/2" Bolt, Hex Nut and Lock Washer.

(2) Use 3/4NC X 6" Bolt, Hex Nut, Lock and Flat Washer with the Flat Washer

on the bottom at location ②. NOTE: Leave Bolts ① & ② loose until after the hydraulic lift cylinder is installed.

(3) Place LOCK PIN for wing lock Part Number 3940-0-2 in the storage hole provided in the wing lift bracket. Secure the pin with Part Number 60-104 SAFETY PINS.

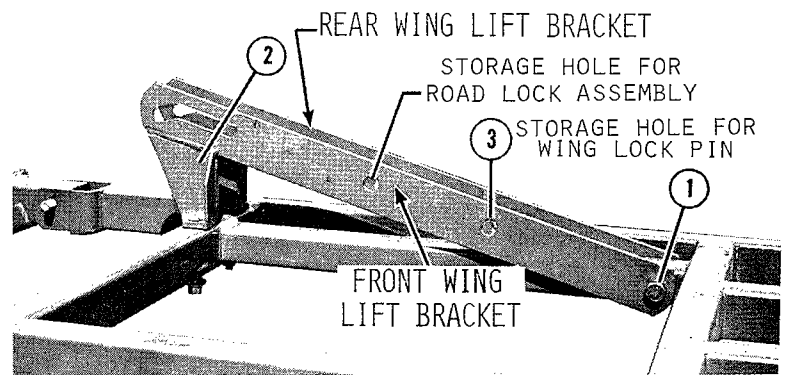

STEP 14. SHANK EXTENSIONS

Turn to page A15 for correct location of shank extensions. All rigid extensions and hinge extensions attach with 3/4NC X 3-1/2" Bolts, Lock Washers, Flat Washers and Hex Nuts.

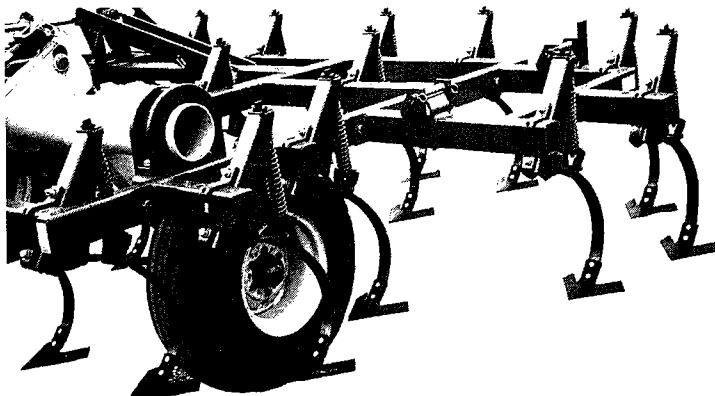
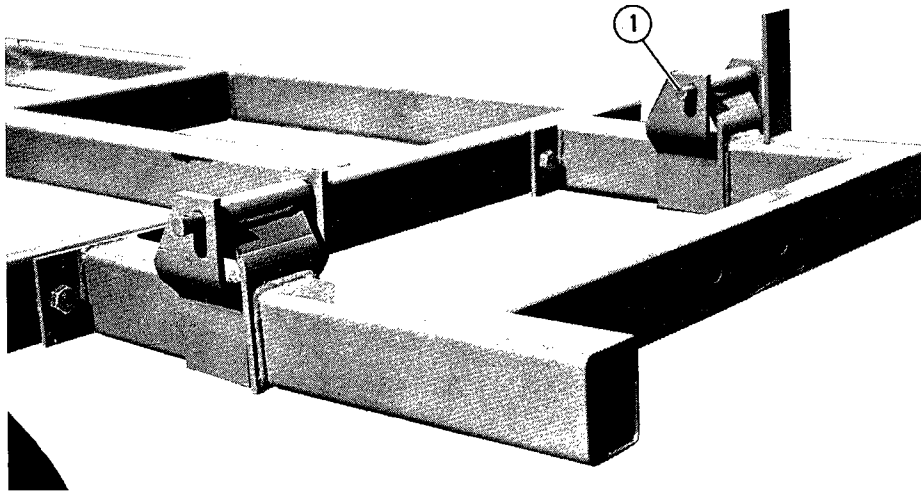

Attach FOLDING EXTENSION to hinge extensions ① with Wing Pin part number 4122-70-1 and Hair Pin Cotter.

STEP 15. HYDRAULICS

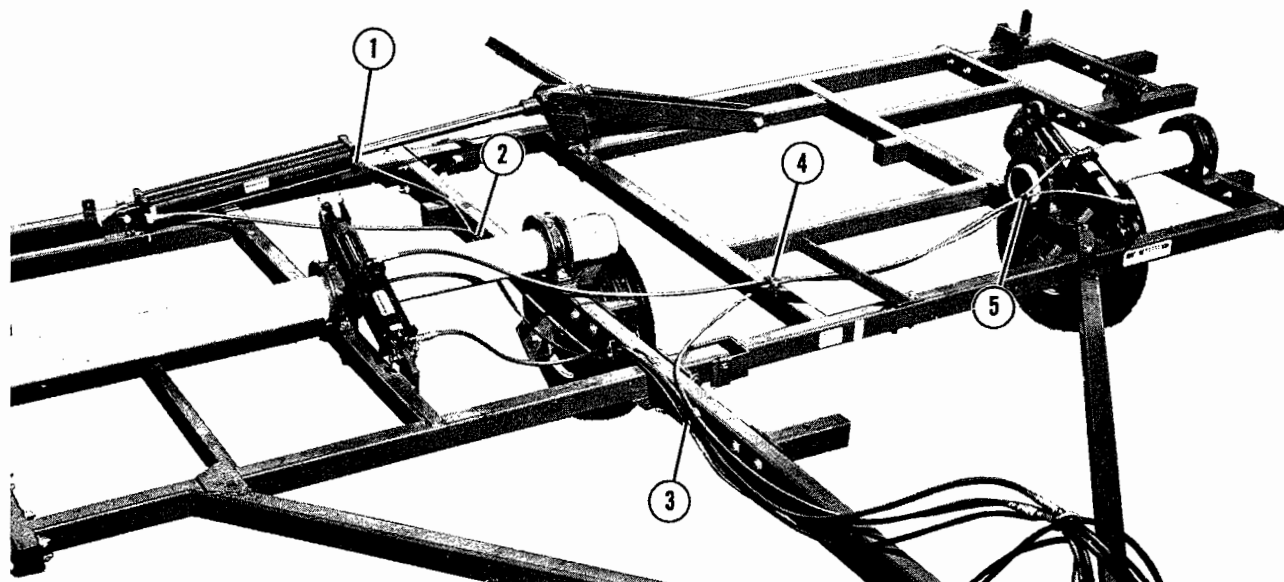

- (1) Pin the base of the 4" Diameter X 32" Wing Lift Cylinder to the lug located at the back of the main section. Block up the end of the cylinder for rod clearance before filling with oil.
- (2) Using the hose and fittings drawings from the "PARTS SECTION" on page P14 attach hoses and fittings to all cylinders.

MAKE SURE SPECIAL RESTRICTOR ELBOW IS IN THE ROD END PORT OF THE WING LIFT CYLINDER ① .

Use liquid pipe sealer at all fitting location. The use of tape type sealers is not recommended, but if tape is used, see instructions below.

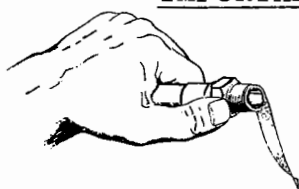

IMPORTANT: IF USING TAPE TYPE SEALERS, START THE TAPE ONE OR TWO THREADS FROM THE END OF THE FITTING TO PREVENT SHREDS OF TAPE FROM ENTERING THE SYSTEM AND PLUGGING THE HYDRAULIC OIL FILTERS. WRAP THE TAPE IN A CLOCKWISE DIRECTION USING APPROXIMATELY 5" OF TAPE PER FITTING, AND MAKING TWO COMPLETE WRAPS.

- (3) Secure hose to frame at locations ② ③ ④ . Clamp hoses together at location ⑤.

STEP 16. FILLING CYLINDERS WITH OIL

CAUTION: CHECK AND MAKE SURE ALL NUTS AND HOSE FITTINGS ON THE CULTIVATOR ARE TIGHT.

DEPTH CONTROL CYLINDERS

- (1) Attach hoses to tractor or hydraulic pump. The 3940 Cultivator hydraulic system requires 10.5 Quarts of oil.
- (2) Begin filling the system by holding the lever open to EXTEND the cylinders. Add oil to the hydraulic power system as required during initial filling.

(2 continued)

After both main section and wing section cylinders are fully extended, hold the valve open for a minimum of 15 seconds.

With cylinders fully extended remove the road lock assembly from the main section cylinder.

Run the cylinders through their complete cycles several times. When you are sure the system is full of oil, extend the rods and use cardboard to check for any leaks in the hose connections. If there are no leaks, pin the road lock assembly over the main section cylinder.

WING LIFT CYLINDER

Block up the end of the cylinder tube so the extending rod will not be obstructed. Attach the correct size tractor couplers to the hose ends and connect to the tractor or hydraulic pump. Fill the cylinder by holding the control lever open at the end of each stroke for a few seconds, forcing oil in and air out. Run the cylinder through its complete cycle several times. When you are sure the system is full of oil, extend the rod.

NOTE: To attach the spring trunnion at the end of the wing lift cylinder between the two loose wing lift weldments, extend the cylinder to the maximum stroke. Raise the outside of the wing until the pivot rods on the sides of the spring trunnion fit into the slots of both weldments. Tighten the loose wing lift bolts, and lower the outside of the wing.



HIGH PRESSURE FLUID FLOW CAN PENETRATE SKIN. IF INJURED BY ESCAPING HYDRAULIC FLUID, SEE A DOCTOR AT ONCE. SERIOUS INFECTION OR REACTION CAN DEVELOP IF PROPER TREATMENT IS NOT ADMINISTERED IMMEDIATELY.

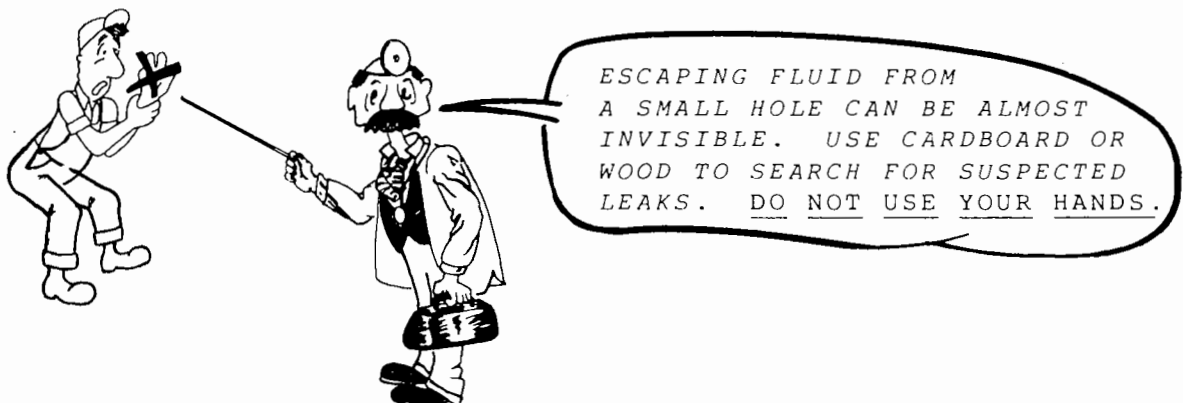

STEP 17. SHANK ASSEMBLY

Refer to Placement Drawings for location of Spring Shanks. If you know whether sweeps or points will be used on the unit being assembled, it may be easier to assemble them to the shank before attaching the shank assembly to the frame.

- (1) Secure Spring Shank Assembly to frame with Clamp Strap ② and (TWO) 1/2NC X 2" Bolts.
- (2) Place Square Flat Washer Plate under head of each bolt inside of Shank Channel ③.
- (3) Secure Bolts with 1/2" STD. Lock Washer and Hex Nuts.

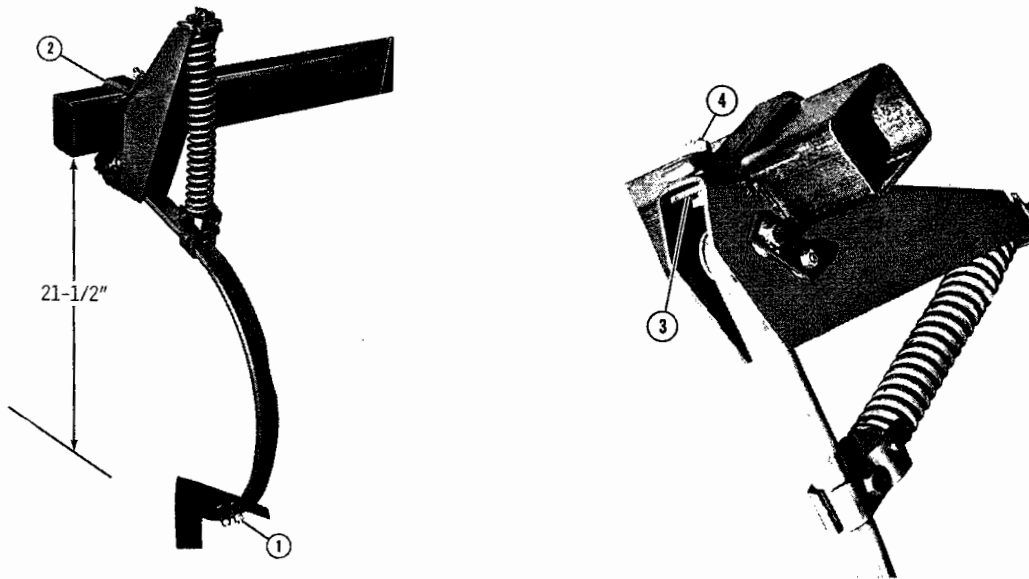

STEP 18. POINTS

1-3/4" points are provided as Optional equipment, or 9" sweeps are available from KRAUSE for use when necessary. When using sweeps other than purchased from KRAUSE, be sure they have a 47° stem angle.

- (1) 1-3/4" width point with 1-3/4" hole centers.
- (2) 9" sweep with 1-3/4" hole centers and 47° stem angle.
- (3) 3/8NC X 1-1/2" GRADE 5 #3 Plow Bolt, Flat Washer (at slotted hole location in shank), Lock Washer and Hex Nut.

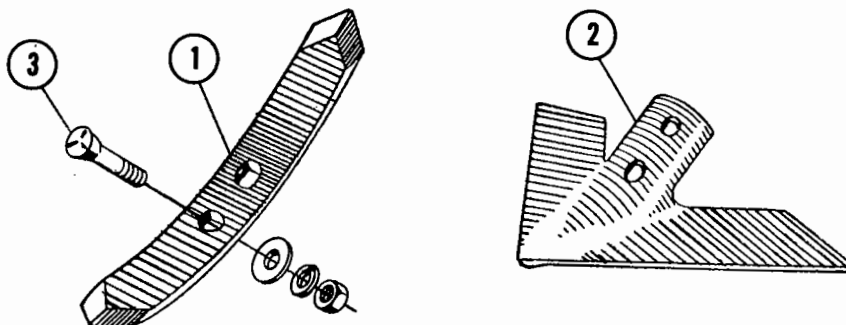

STEP 19. LAMP BRACKET

Attach LAMP BRACKET to rear frame beam of main section with a 7/16NC X 1" Carriage Bolt, Lock Washer and Hex Nut.

STEP 20. DECALS

The DECALS are important to the safety of the operators and to others and must be attached at the proper locations. Some DECALS are applied to the proper location at the factory, however, these should be checked for location and to be sure they have not been damaged in shipping or set-up. Remove the protective backing from each remaining decal, and attach to the field cultivator at the locations shown below.

- | | | | | | |
|---|--------|-----------------------------------|---|--------|----------------------|
| ① | 74-117 | IMPLEMENT SAFETY DECAL | ⑥ | 74-101 | KRAUSE DECAL (Large) |
| ② | 74-121 | CAUTION - WIDTH - HEIGHT DECAL | ⑦ | 74-139 | 3900 SERIES DECAL |
| ③ | 74-107 | YELLOW REFLECTOR | ⑧ | 74-144 | LAMP BRACKET |
| ④ | 74-108 | RED REFLECTOR | ⑨ | 74-100 | KRAUSE DECAL (Small) |
| ⑤ | 74-102 | DANGER! STAND CLEAR OF WING DECAL | ⑩ | 74-142 | EXTENSION DECAL |

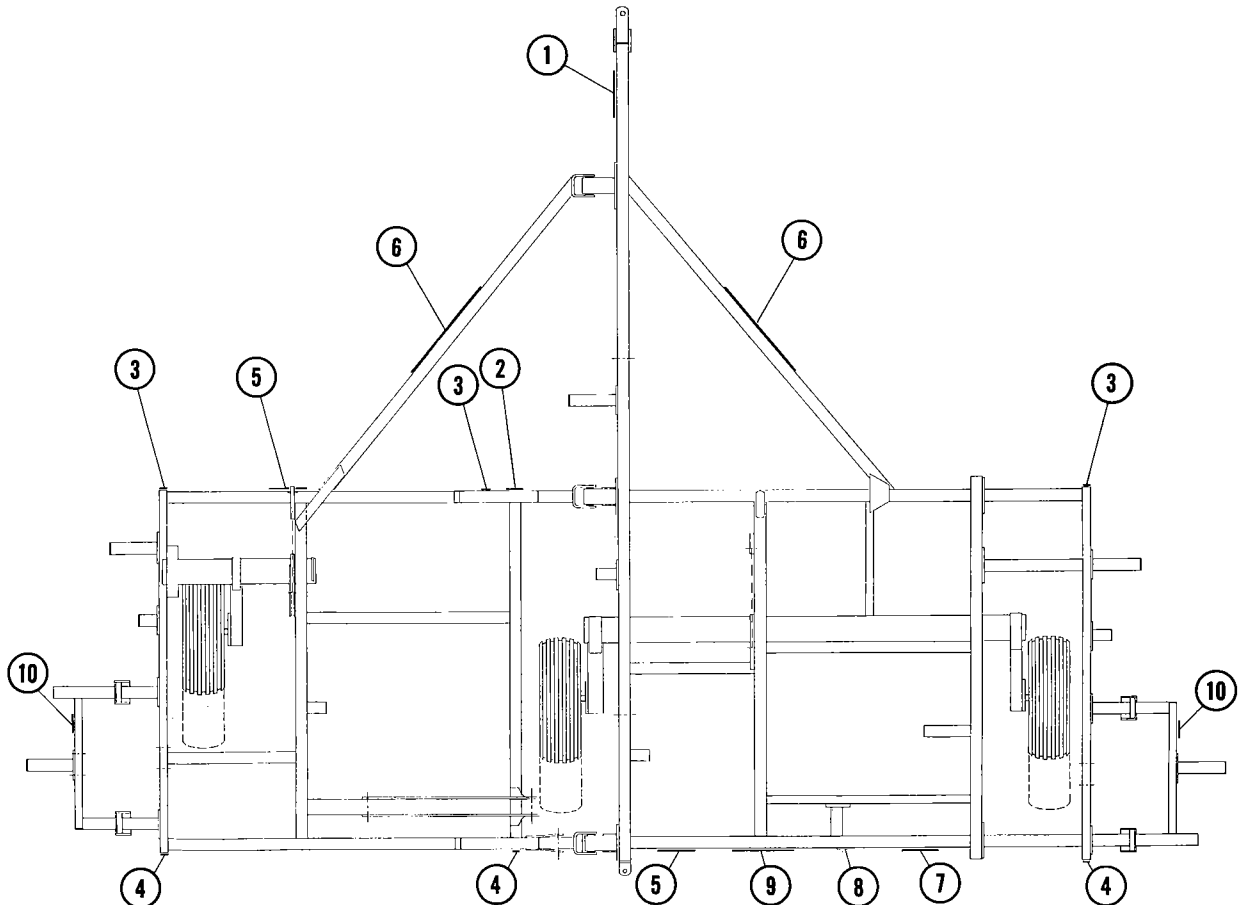

MODEL 3940

3940-60-0 EXTENSION BOLT SACK
FOR 36 SHANK RIGID

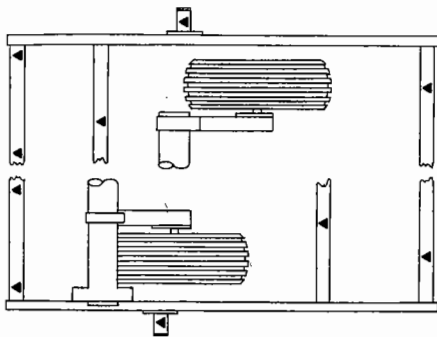

3940-61-0 EXTENSION BOLT SACK
FOR 38 SHANK RIGID

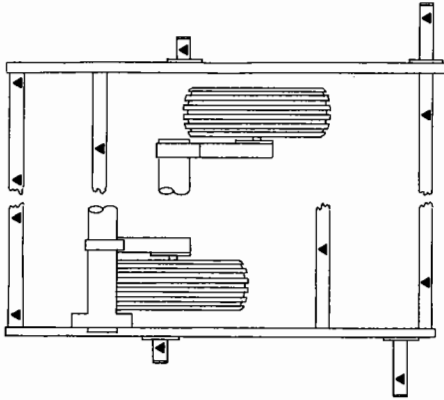

3940-62-0 EXTENSION BOLT SACK
FOR 40 SHANK RIGID

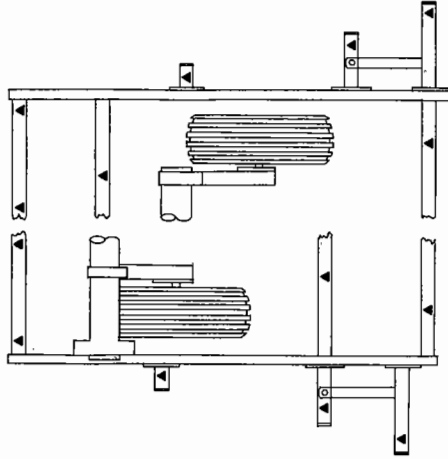

3940-63-0 EXTENSION BOLT SACK
FOR 40 SHANK FOLDING

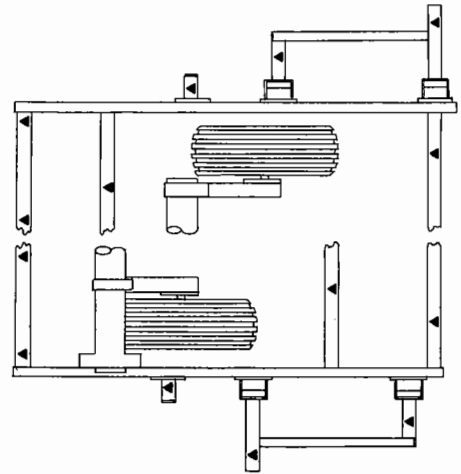

3940-64-0 EXTENSION BOLT SACK
FOR 42 SHANK FOLDING

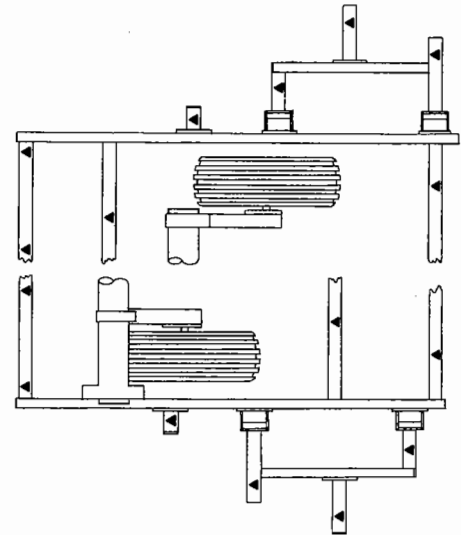

3940-65-0 EXTENSION BOLT SACK
FOR 44 SHANK FOLDING

